

Burner control units BCU 570

TECHNICAL INFORMATION

- For monitoring and controlling modulating individual burners and forced draught burners of unlimited capacity
- For directly ignited burners or burners ignited by a pilot burner in intermittent or continuous operation
- Perform safety functions in accordance with EN 746-2 and EN 676
- With optional valve proving system
- Flexible range of applications due to parameterization possibilities
- Optional bus module for fieldbus connection



Contents

Inhaltsverzeichnis	2
1 Application	5
1.1 Application examples	7
1.1.1 Modulating-controlled forced draught burner	7
1.1.2 Modulating-controlled forced draught burner with valve proving system	8
1.1.3 Modulating-controlled forced draught burner with pilot burner and valve proving system	9
1.1.4 Limitation of the ignition rate in accordance with SIL/PL	10
1.1.5 Controlling the BCU via PROFINET	12
1.1.6 Controlling the BCU and the butterfly valve via PROFINET	12
2 Certification	13
2.1 Certificate download	13
2.2 Certified to SIL and PL	13
2.3 EU certified	13
2.4 ANSI/CSA approved	13
2.5 FM approved	13
2.6 UL listed	13
2.7 AGA approved	13
2.8 Eurasian Customs Union	14
3 Function	15
3.1 Part designations	15
3.2 Connection diagram	16
3.2.1 BCU 570 with ionization control in double-electrode operation	16
3.2.2 Flame control	17
3.2.3 Assignment of connection terminals	18
3.2.4 Program sequence	21
4 Air control	22
4.1 Controlled air flow	23
4.2 Capacity control	24
5 Valve proving system	25
5.1 Tightness control	25
5.1.1 Test instant	26
5.1.2 Program sequence	27
5.2 Test period t_P	29
5.2.1 Extended valve opening time t_L	30
5.2.2 Measurement time t_M	31
5.3 Proof of closure function	34
5.3.1 Program sequence	34
6 BCSoft	35
7 Fieldbus communication	36
7.1 BCU 570 and bus module BCM	37
7.2 Configuration, planning	38
7.2.1 Device master data file (GSD)	38
7.2.2 Modbus TCP	38
7.2.3 Modules/Registers for process data	39
7.2.4 Device parameters and statistics	44
8 Program step/status	45
9 Fault messages	46
10 Parameter	48
10.1 Scanning the parameters	52
10.2 Flame control	52
10.2.1 Burner 1 flame signal FS1 switch-off threshold	52
10.2.2 Flame control	52
10.3 Behaviour during start-up	53
10.3.1 Burner 1 start-up attempts	53
10.3.2 Start-up with pre-purge after controlled shut-down within 24 hours	54
10.3.3 Burner application	55
10.3.4 Pre-ignition time t_{VZ}	57
10.3.5 Safety time 1 t_{SA1}	58
10.3.6 Flame proving period 1 t_{FS1}	58
10.3.7 Safety time 2 t_{SA2}	59
10.3.8 Flame proving period 2 t_{FS2}	59
10.4 Behaviour during operation	60
10.4.1 Restart	60
10.4.2 Minimum operating time t_B	62

10.4.3 Pilot burner	62	11.1 Type code	90
10.5 Safety limits	63	12 Project planning information	91
10.5.1 Emergency stop	63	12.1 Installation	91
10.5.2 High gas pressure protection	63	12.2 Commissioning	91
10.5.3 Low gas pressure protection	64	12.3 Electrical connection	92
10.5.4 Low air pressure protection	64	12.3.1 OCU	92
10.5.5 Safety time during operation t_{SB}	65	12.3.2 Safety current inputs	93
10.6 Air control	66	12.4 Actuators	94
10.6.1 Fan run-up time t_{GV}	66	12.4.1 IC 20	94
10.6.2 Air monitoring during controlled air flow	66	12.5 Air control	94
10.6.3 Pre-purge time t_{PV}	66	12.6 Parameter chip card	94
10.6.4 Air flow monitoring during pre-purge	67	13 Accessories	95
10.6.5 Post-purge time t_{PN}	67	13.1 BCSoft4	95
10.6.6 Air flow monitoring during post-purge	67	13.1.1 Opto-adapter PCO 200	95
10.6.7 Capacity control	68	13.2 OCU	95
10.6.8 Running time selection	76	13.3 Accessories set BCU 5xx/OCU	96
10.6.9 Running time	76	13.4 Connection plug set	96
10.6.10 Low fire over-run	77	13.5 Stickers for labelling	96
10.6.11 Controller enable signal delay time t_{RF}	77	13.6 "Changed parameters" stickers	97
10.6.12 Capacity control (bus)	78	14 OCU	98
10.7 Valve check	83	14.1 Application	98
10.7.1 Valve proving system	83	14.2 Function	99
10.7.2 Relief valve (VPS)	83	14.2.1 Manual mode	99
10.7.3 Measurement time for V_{p1}	84	14.3 Electrical connection	100
10.7.4 Valve opening time 1 t_{L1}	84	14.4 Installation	100
10.8 Behaviour during start-up	85	14.5 Selection	100
10.8.1 Minimum pause time t_{MP}	85	14.6 Technical data for OCU	101
10.8.2 Switch-on delay time t_E	85	15 BCM 500	102
10.9 Manual mode	86	15.1 Application	102
10.9.1 Operating time in Manual mode	86	15.2 Function	102
10.10 Functions of terminals 51, 65, 66, 67 and 68	87	15.3 Electrical connection	102
10.10.1 Function of terminal 51	87	15.4 Installation	103
10.10.2 Function of terminal 65	87	15.5 Selection	103
10.10.3 Function of terminal 66	88		
10.10.4 Function of terminal 67	88		
10.10.5 Function of terminal 68	88		
10.10.6 Password	89		
10.10.7 Fieldbus communication	89		
11 Selection	90		

15.6 Technical data for BCM	104
16 Technical data	105
16.1 Electrical data	105
16.2 Mechanical data	106
16.3 Ambient conditions	106
16.4 Dimensions	106
16.5 Safety-specific characteristic values	107
17 Converting units	108
18 Maintenance	109
19 Legend	110
20 Glossary	111
20.1 Waiting time t_W	111
20.2 Ignition time t_Z	111
20.3 Safety interlocks (Limits)	111
20.4 Safety time on start-up t_{SA1}	111
20.5 Safety time during operation t_{SB}	111
20.6 Safety shut-down	112
20.7 Fault lock-out	112
20.8 Warning signal	113
20.9 Timeout	113
20.10 Lifting	113
20.11 Air valve	113
20.12 Diagnostic coverage DC	113
20.13 Operating mode	114
20.14 Safe failure fraction SFF	114
20.15 Probability of dangerous failure PFH_D	114
20.16 Mean time to dangerous failure $MTTF_d$	114
For more information	115

1 Application



BCU 570 with plug-in spring-force connection terminals

Burner control unit BCU 570 controls, ignites and monitors industrial individual burners and forced draught burners of unlimited capacity in intermittent or continuous operation. It can be used for directly ignited burners or burners ignited by a pilot burner.

The BCU 570 has an interface for control elements for burner capacity control. Both actuators (IC 20, IC 40, 3-point step and RBW) and frequency converters can be controlled. A valve proving system can be integrated as an option.

The BCU 570 activates the fan and sets a connected actuator or frequency converter to pre-purge and ignition positions.

If the centrally checked safety requirements, e.g. pre-purge, flow detector and pressure switch check, have been met, the BCU 570 starts the burner. An enable signal is then issued to an external temperature controller which controls the actuator or frequency converter in accordance with the capacity demand.

The burner control unit BCU 570 monitors the gas and air pressure. The optionally integrated valve proving system checks the valves by checking an external gas pressure switch or by checking whether the gas valve on the inlet side is closed.

Using the BCSoft program, the parameters, analysis and diagnostic information can be read from the BCU via the optionally available opto-adapter. All valid parameters are saved on the integrated parameter chip card. The parameter chip card can be removed easily, for example when the unit is replaced, and inserted into a new BCU to transfer the parameters.

An integrated Manual mode allows the manual activation of the burner control units and adjustment of the butterfly valves.

The fan output and the actuator and valve outputs which are checked for faults are accommodated in a plug-in power module. This can easily be replaced if necessary.



Once the plug-in power module has been removed, the parameter chip card and fuses are accessible.

1 Application

The BCU can be installed on a DIN rail in the control cabinet. The plug-in connection terminal strips make it easier to install and remove.

The external operator-control unit OCU is available as an option for the BCU. The OCU can be installed in the control cabinet door instead of standard control units. The program step/status or fault messages can be read on the OCU. For burner adjustment, the operating points can be approached conveniently in Manual mode using the operator-control unit.



Thanks to the operator-control unit OCU, display functions and operation of the BCU can be relocated to the control cabinet door.

Using the bus module BCM 500, the BCU can be networked with a fieldbus system. Networking in a fieldbus system enables the burner control unit BCU 570 to be controlled and monitored by an automation system (e.g. PLC). This also opens up a wide range of process visualization possibilities.



Bus module BCM 500 for DIN rail installation for lateral connection to the BCU

1.1 Application examples

1.1.1 Modulating-controlled forced draught burner

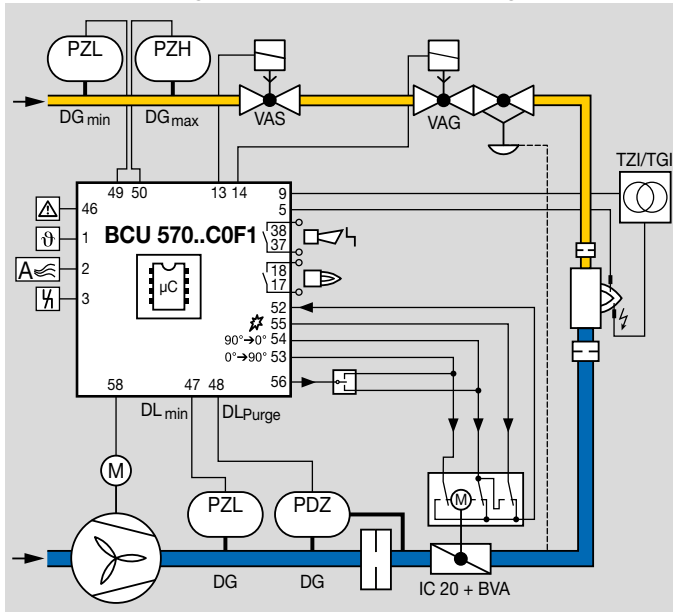

The BCU 570 controls the fan, monitors the combustion media air and gas, controls pre-purge and moves the butterfly valve to pre-purge and ignition positions. Once the BCU 570 has started the burner, it issues the enable signal to the external temperature controller which then assumes the control task.

1.1.2 Modulating-controlled forced draught burner with valve proving system

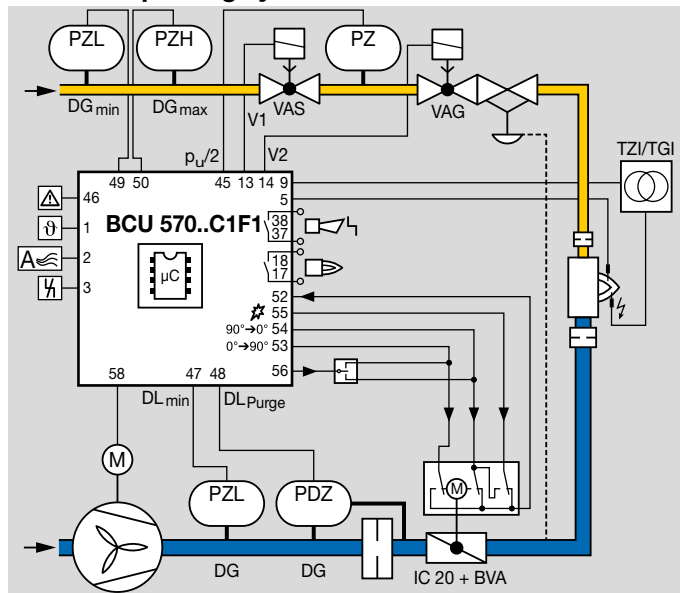

The BCU 570..C1 is fitted with an integrated valve proving system. This allows the tightness of two gas solenoid valves and the pipework to be checked. Optionally, the closed position of a gas solenoid valve can also be checked using a POC switch.

The tightness control function satisfies the requirements of EN 1643 (Valve proving systems for automatic shut-off valves for gas burners and gas appliances).

By checking the closed position using the proof of closure function, the BCU complies with the requirements of NF-PA 85 (Boiler and Combustion Systems Hazards Code) and NFPA 86 (Standard for Ovens and Furnaces).

1.1.3 Modulating-controlled forced draught burner with pilot burner and valve proving system

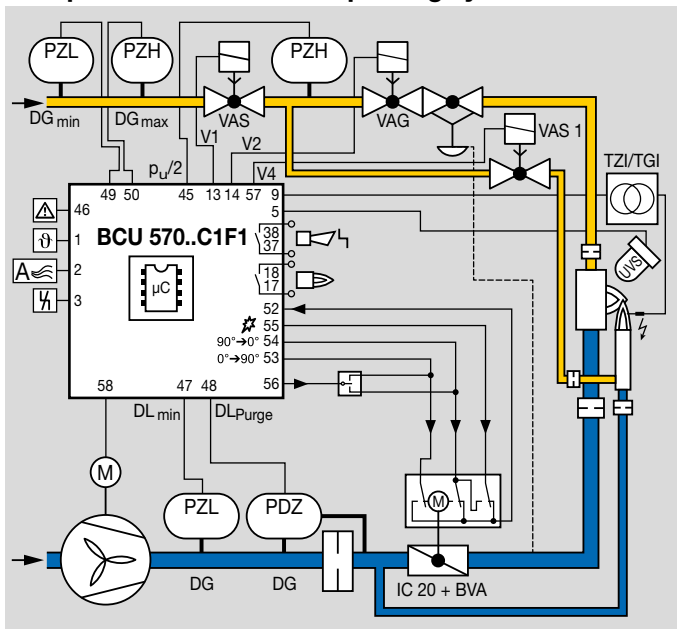

The burner is ignited by a pilot burner. The integrated valve proving system checks the tightness of all gas valves and the pipework between the gas solenoid valves with the aid of the pressure switch.

Parameters may be used to decide whether the pilot burner should be operated permanently or is switched off during the main burner's safety time.

1 Application

The safe limitation of the ignition rate can be used for both applications with a single burner and burners with pilot burners.

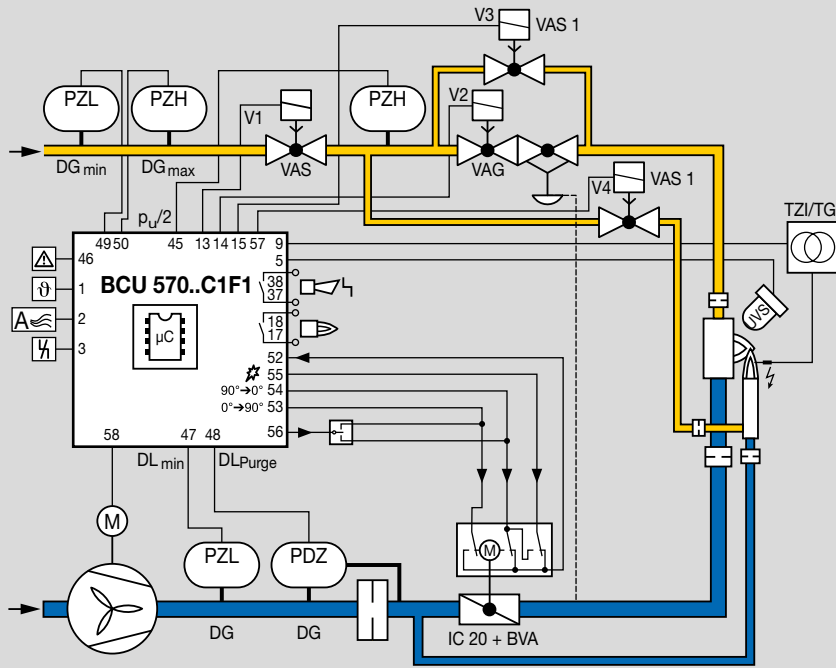

1.1.5 Controlling the BCU via PROFINET

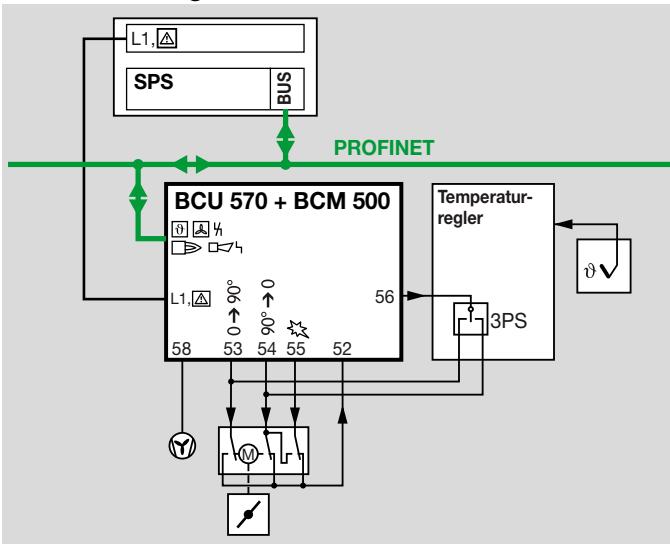

The BCU issues the enable signal to the temperature controller for capacity control. After it has been enabled, the butterfly valve is controlled directly by the temperature controller.

1.1.6 Controlling the BCU and the butterfly valve via PROFINET

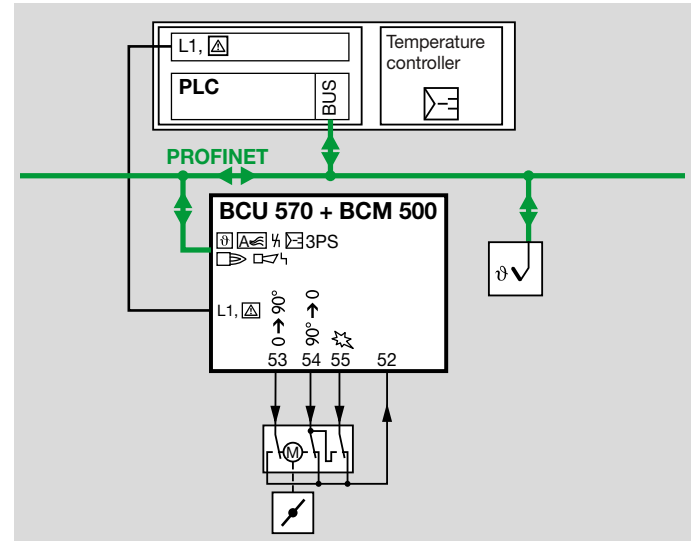

The BCU receives positioning information for the butterfly valve from the temperature controller via PROFINET and activates the butterfly valve following controller enable.

2 Certification

2.1 Certificate download

Certificates – see www.docuthek.com

2.2 Certified to SIL and PL



For systems up to SIL 3 pursuant to EN 61508. Pursuant to EN ISO 13849-1, Table 4, the BCU can be used up to PL e. See page 107 (16.5 Safety-specific characteristic values).

2.3 EU certified



- 2014/35/EU (LVD), Low Voltage Directive
- 2014/30/EU (EMC), Electromagnetic Compatibility Directive
- (EU) 2016/426 (GAR), Gas Appliances Regulation

2.4 ANSI/CSA approved



American National Standards Institute/Canadian Standards Association – ANSI Z21.20/CSA C22.2, No. 199/UL 372, Class number: 3335-01 (natural gas, LPG), 3335-81 (natural gas, propane).

2.5 FM approved



Factory Mutual Research Class: 7610 Combustion Safeguards and Flame Sensing Systems. Designed for applications pursuant to NFPA 85 and NFPA 86.

2.6 UL listed



Underwriters Laboratories – UL 372 “Primary Safety Controls for Gas and Oil-Fired Appliances”.

2.7 AGA approved



Australian Gas Association, Approval No.: 8321
www.aga.asn.au

2.8 Eurasian Customs Union

The logo for the Eurasian Customs Union (EAC) is displayed in a bold, black, sans-serif font. The letters 'E', 'A', and 'C' are closely spaced and centered within a light gray rectangular background.

The products BCU 570 meet the technical specifications of the Eurasian Customs Union.

3 Function

3.1 Part designations

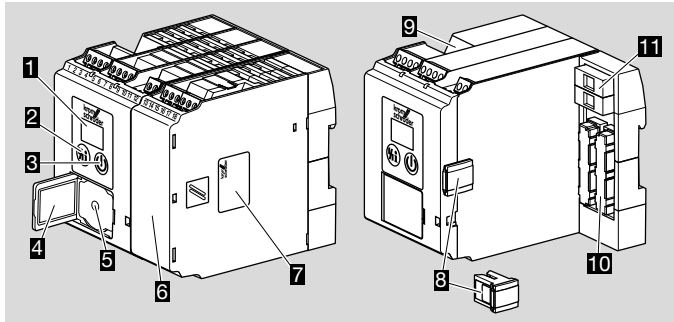

1	LED display for program status and fault messages To display the program status or fault message and, in conjunction with the Reset/Information button, to display the flame signal and the fault history or to view and set device parameters.
2	Reset/Information button To reset the control unit to its starting position in the event of a fault. System faults (internal errors) can only be acknowledged using this button.
3	On/Off button To switch the control unit on or off
4	BCU type label Visible when the hinged cover is open
5	Connection for opto-adaptor
6	Power module, replaceable
7	Power module type label
8	Parameter chip card (PCC), replaceable
9	OCU connection terminals
10	Contact strip for power module
11	Device fuses, replaceable

There are two control keys for the control unit:

	ON/OFF Use the ON/OFF key to switch the control unit on or off.
	Reset/Information The control unit is reset to its starting position in the event of a fault using the Reset/Information button.

During operation, the LED display **1** shows the program status. The flame signal intensity, the fault history and the parameters can be called up on the display by repeatedly pressing the Reset/Information button (for 1 s). The parameter display is ended 60 seconds after the last time the button is pressed or by switching off the BCU. When the BCU is switched off, -- is displayed. The parameters cannot be scanned when the BCU is switched off or when a fault/warning is displayed.

Display	Information
<i>Fl</i>	Burner 1 flame signal intensity
<i>E0</i> to <i>E9</i>	Last fault message to tenth to last fault message
<i>01</i> to <i>99</i>	Parameter 01 to Parameter 99

3.2 Connection diagram

3.2.1 BCU 570 with ionization control in double-electrode operation

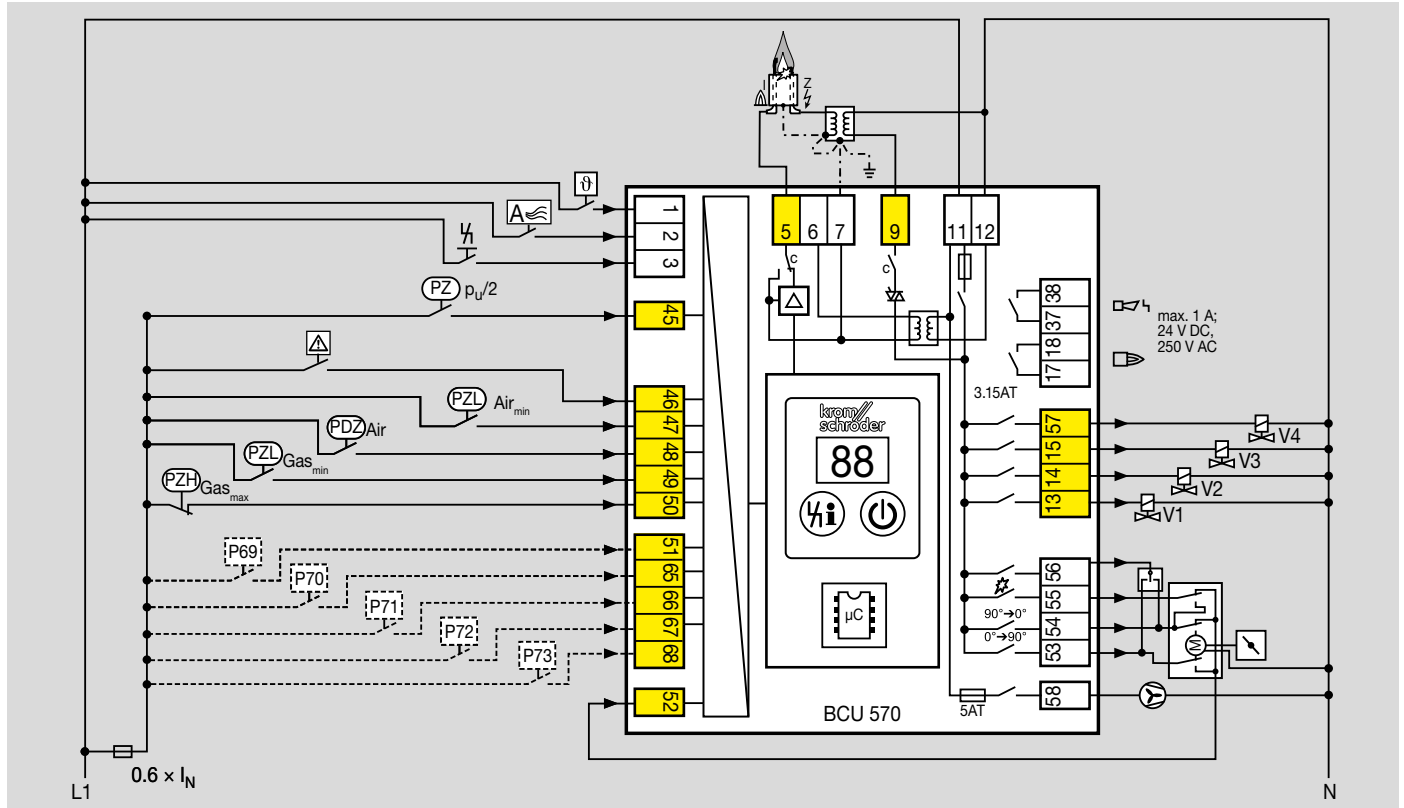

Connection diagrams for actuators and frequency converters, see page 68 (10.6.7 Capacity control)

Explanation of symbols, see page 110 (19 Legend)

Electrical connection, see Project planning information, page 92 (12.3 Electrical connection)

3.2.2 Flame control

With ionization control in single-electrode operation

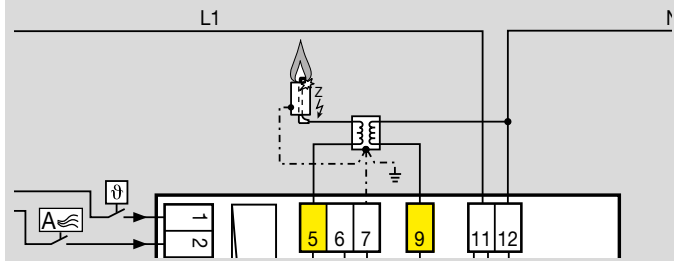

With parallel ionization control of pilot/main burner

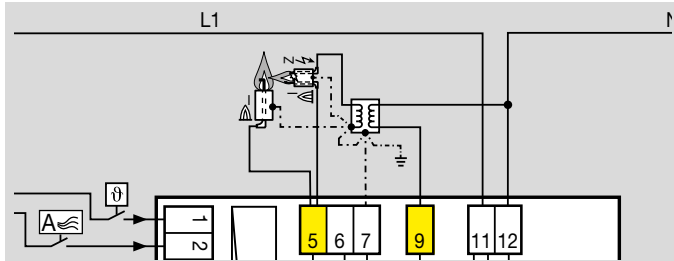

Two flame rods can be connected in parallel to the ionization input. This is necessary, for example, if a pilot/main burner combination needs to be monitored where both the pilot and the main burner are fitted with a flame rod.

With parallel ionization control of pilot burner and UV control of main burner

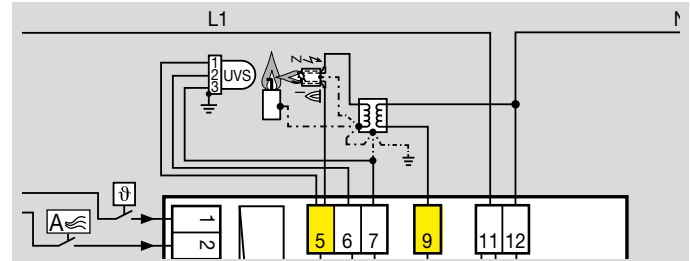

With UVS control

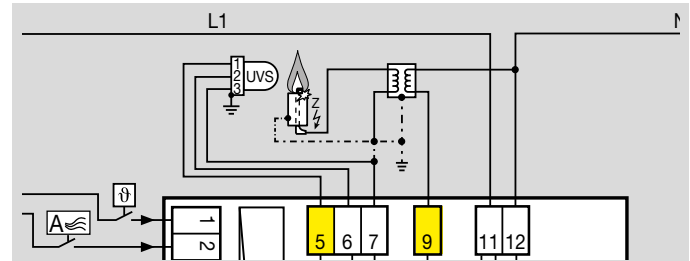

With UVC control

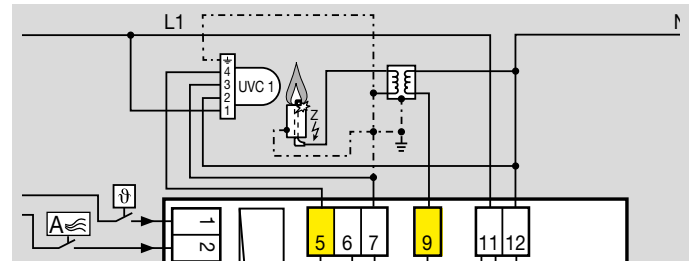

3.2.3 Assignment of connection terminals

Control input (AC mains voltage)

Terminal	Designation	Function
1	Start-up signal	Signal applied: heating start; no signal: heating stop
2	Controlled air flow	Signal applied: fan is started to supply air to the combustion chamber for cooling, for example. Controlled air flow is only possible in standby with deactivated start-up signal. As soon as heating operation is started (start-up signal at terminal 1), the function is interrupted.
3	Remote reset	Input for external signal (button) to reset the unit after a fault lock-out. System faults (internal errors) can only be acknowledged using this button.

Input (μA)

Terminal	Designation	Function
5	Flame signal	Connection for flame rod/UV sensor/ignition transformer

Output

Terminal	Designation	Function
6	UV sensor	Voltage supply for UV sensor UVS

Ground

Terminal	Designation	Function
7	Burner ground	Connection to be connected to the electrically conductive structure of a burner/furnace

Output (AC mains voltage)

Terminal	Designation	Function
9	Ignition	Connection for an ignition transformer or ignition unit

Supply (AC mains voltage)

Terminal	Designation	Function
11, 12	Supply voltage	Voltage to operate the BCU, 11 = phase (L1), 12 = neutral conductor (N)

Valve outputs (AC mains voltage)

Terminal	Designation	Function
13	Gas valve V1	Connection of phase for gas valve V1
14	Gas valve V2	Connection of phase for gas valve V2
15	Gas valve V3	Connection of phase for gas valve V3
57	Gas valve V4	Connection of phase for gas valve V4

Floating contact

Terminal	Designation	Function
17, 18	Operating signal	Contact between terminals 17 and 18 closes once the operating signal has been received from the burner
37, 38	Fault signal	Contact between terminals 37 and 38 closes in the event of a BCU fault lock-out

Safety circuit input (AC mains voltage)

Terminal	Designation	Function
45	Valve proving system	Connection for the sensor of the valve proving system (pressure switch for tightness test or POC switch for checking the closed position)
46	Controller enable/Emergency stop	Connection for higher-level safety devices and interlocks (e.g. emergency stop), see page 63 (10.5.1 Emergency stop)
47	Minimum air pressure	Connection for pressure switch to monitor the minimum air pressure, see page 64 (10.5.4 Low air pressure protection)
48	Minimum air flow	Connection for a sensor to monitor the minimum air flow during pre-purge or post-purge, see page 67 (10.6.4 Air flow monitoring during pre-purge) and page 67 (10.6.6 Air flow monitoring during post-purge)
49	Minimum gas pressure	Connection for pressure switch to monitor the minimum gas pressure, see page 64 (10.5.3 Low gas pressure protection)
50	Maximum gas pressure	Connection for pressure switch to monitor the maximum gas pressure, see page 63 (10.5.2 High gas pressure protection)
51, 65, 66, 67, 68	Programmable fail-safe inputs	The terminals can be assigned a function using parameters. To do so, logical AND gatings with terminals 46, 47, 48, 49 or 50 are possible, for example.
52	Feedback from actuator/frequency converter	Feedback input for minimum and maximum capacity

3 Function

Outputs (AC mains voltage)

Terminal	Designation	Function
53, 54, 55, 56	Capacity control	Connection for capacity control using an actuator or frequency converter, see Parameters 40 to 47
58	Fan	Connection for fan control. If the fan is not controlled by the BCU, this output can be used as an alternative to control a valve for the air pressure switch function check.

3.2.4 Program sequence

	Switch on BCU 570
	▼
	In the event of fault signal: reset
	▼
00	Start-up position/Standby Start-up with start-up signal
	▼
H0	Switch-on delay time t_E running (P62 or P63)
	▼
01	Fan run-up time t_{GV} (P30)
	▼
R0	Actuator moves to the position for maximum capacity
	▼
d l	Low air pressure protection check
	▼
P1	Pre-purge time t_{PV} running (P34) Tightness test starts (if parameterized)
	▼
Ri	Actuator moves to the position for ignition capacity
	▼
03	Pre-ignition time t_{VZ} running (P93) Ignition activated
	▼
04	Safety time t_{SA1} running for burner/pilot burner (P94), V1 and V2 open
	▼
04	Pilot burner operation signalling contact closes, valve for 2 nd gas stage opens and min. operating time t_B starts to elapse (A061)
05	Flame proving period t_{FS1} running for burner/pilot burner (P95)
	▼
06	Safety time t_{SA2} running for main burner (P96), V3 opens
	▼

06	If parameter P79 = 0: V4 is switched off
	▼
07	Flame proving period 2 t_{FS2} running (P97)
	▼
H8	Controller enabler signal delay time t_{RF} (P44)
	▼
08	Controller enable/operation
	▼
08	Controlled shut-down via start-up signal
	▼
R0	Actuator moves to the position for maximum capacity
	▼
P9	Post-purge time t_{PN} running (P37)
	▼
Rc	Actuator moves to the position for minimum capacity or the closed position
	▼
d 0	Air monitor "no flow" state
	▼
00	Start-up position/Standby

4 Air control

The BCU 570 takes over the air control as it is the central protective system. It controls and monitors the required air volume for start-up and after the burner has been shut down. The capacity control is enabled while the burner is in operation.

The BCU 570 activates the fan. The static air pressure and the air volume for pre-purge are monitored.

3-point step actuators (for example IC 20, IC 20..E) or IC 40 actuators can be controlled and monitored via the interfaces on the BCU 570..F1. RBW actuators or frequency-controlled fans can be controlled and monitored via the interfaces on the BCU..F2. The actuator or fan is controlled by an external temperature controller.

4.1 Controlled air flow

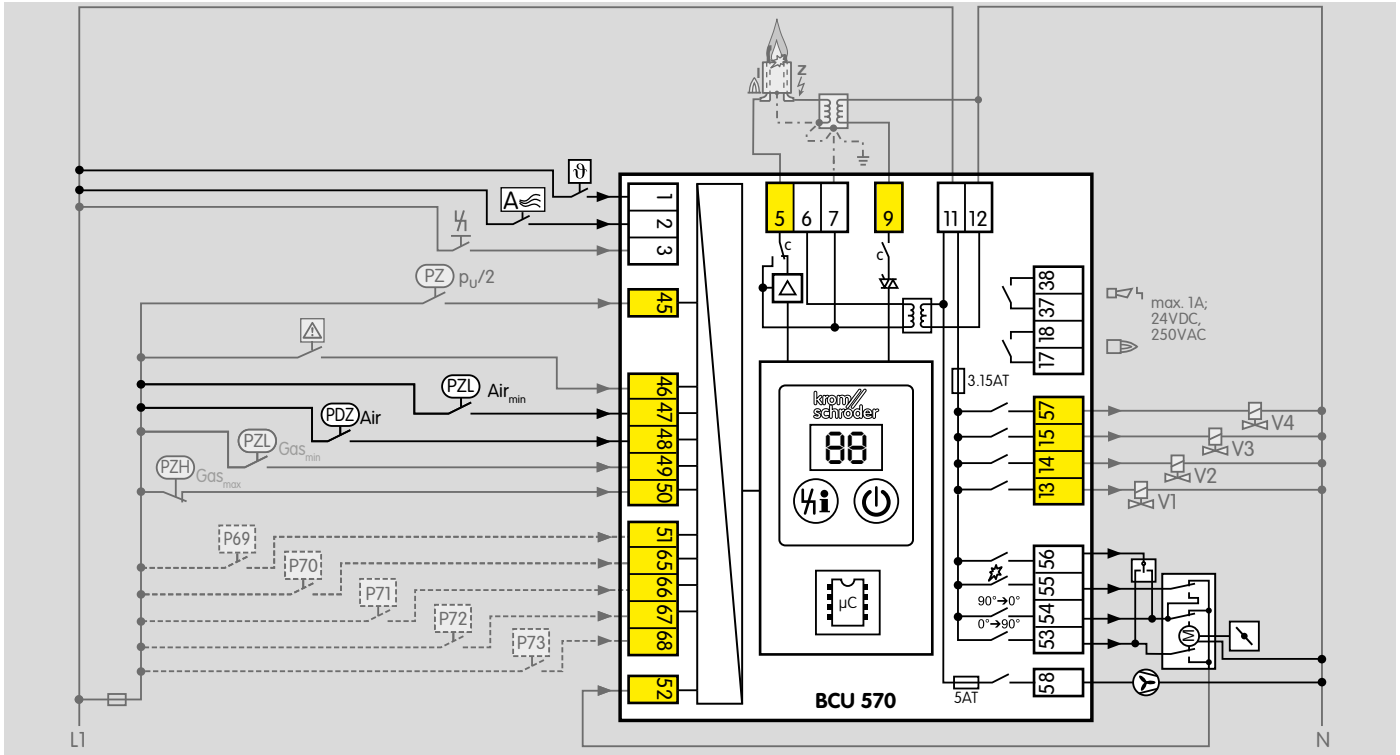

If the external air control input (terminal 2) is actuated in standby (without a start-up signal), the BCU will start the fan to provide air to cool the combustion chamber, for example.

The fan is started depending on the functions defined using parameters, see page 64 (10.5.3 Low gas pressure protection), page 85 (10.8.2 Switch-on delay time tE), page 66 (10.6.1 Fan run-up time tGV), page 66 (10.6.2 Air monitoring during controlled air flow).

As soon as a start-up signal is received at terminal 1, the controlled air flow function is stopped and a burner start is initiated.

4.2 Capacity control

The BCU 570 activates a control element via the outputs for capacity control (terminals 53 to 56) for controlled air flow, pre- and post-purge or to start the burner. This control element (butterfly valve or frequency converter) is used to set the air volume required for the relevant operating situation.

As soon as a start-up signal is received by the BCU 570 (terminal 1), the fan is started after the switch-on delay time has elapsed. The air volume for pre-purge is set using the control element via the outputs for capacity control (terminals 53 to 56). If the fan is switched on, the minimum air pressure is ensured using an air pressure switch connected to terminal 47. The pre-purge time starts if there is adequate air flow.

After the elapse of the pre-purge time, the air volume for ignition is set using the control element. If the air volume has been set and the valve check (BCU 570..C1) completed, the burner will be ignited. After the operating signal has been received from the burner and after expiry of the delay time for the controller enable signal (P44), the BCU issues the controller enable signal. Access to the control element is thus transferred to an external temperature controller. The temperature controller controls the burner capacity (air volume) on the basis of the required temperature.

Depending on the wiring for the output signals of the temperature controller (3-point step), the actuator may be adjusted between maximum capacity and ignition capacity or minimum capacity.

Depending on parameter 40, actuators IC 20 and IC 40, an actuator with an RBW interface or a fan controlled by a frequency converter can be actuated via the outputs for capacity control. For more detailed information about capacity control with actuators IC 20 and IC 40, RBW interface or

frequency converter, see page 68 (10.6.7 Capacity control).

As soon as the start-up signal (terminal 1) is switched off, the post-purge time starts to elapse. Depending on the parameter setting, the butterfly valve moves to the position for ignition capacity and then to the position for minimum capacity or the closed position. Next, the BCU rests in the start-up position/standby.

5 Valve proving system

The BCU..C1 is fitted with an integrated valve proving system. This allows the tightness of two or more gas solenoid valves and the pipework to be checked, see page 25 (5.1 Tightness control).

Alternatively, the closed position of a gas solenoid valve can be checked using a POC switch, see page 34 (5.3 Proof of closure function).

Once the test has been carried out successfully, the furnace is enabled for start-up.

5.1 Tightness control

The aim of the tightness control is to identify an inadmissible leak on one of the gas solenoid valves and to prevent burner start. Gas solenoid valves V1 and V2 are tested as is the pipework between the valves.

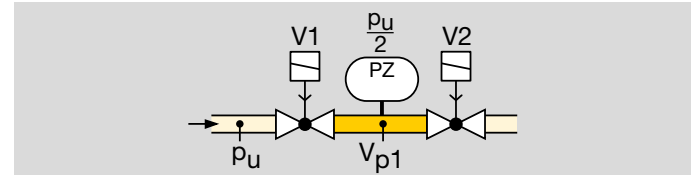

💡 European standards EN 746-2 and EN 676 stipulate tightness controls for capacities over 1200 kW (NF-PA 86: from 117 kW or 400,000 Btu/h).

💡 The tightness control function satisfies the requirements of EN 1643 (Valve proving systems for automatic shut-off valves for gas burners and gas appliances).

5.1.1 Test instant

Depending on the parameter setting, the tightness control checks the tightness of the pipework and the gas solenoid valves before each start-up and/or after each shut-down of the burner, see page 83 (10.7.1 Valve proving system).

The gas line is always safeguarded by a gas solenoid valve during this check.

Before burner start-up

The valve check is started when the start-up signal is present at terminal 1. The BCU checks the tightness of the gas solenoid valves and the pipework between the valves. The gas line is always safeguarded by a gas solenoid valve during this check. The burner is ignited when pre-purge is ended and the tightness has been checked successfully.

After burner shut-down

After the burner has been shut down, the BCU checks the tightness of the gas solenoid valves and the pipework between them. Once the test has been carried out successfully, the next burner start is enabled. The BCU immediately conducts a tightness test if mains voltage is available or if it is reset after a fault lock-out.

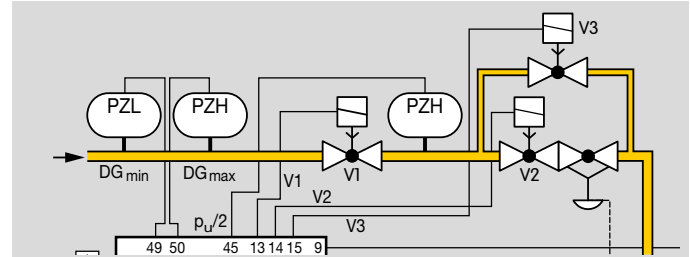

An additional bypass/relief valve must be installed in gas sections with an air/gas ratio control. This ensures that the test volume V_{p1} can be vented during the tightness test with the air/gas ratio control closed.

5 Valve proving system

5.1.2 Program sequence

The tightness test starts by checking the external pressure switch.

If pressure p_Z between inlet valve V1 and outlet valve V2 is greater than half the inlet pressure p_U ($p_Z > p_U/2$), program A starts.

If pressure $p_Z < p_U/2$, program B starts.

Program A

Valve V1 opens for the opening time t_L set in parameter 59. V1 closes again. During the measurement time t_M , the tightness control checks the pressure p_Z between the valves.

If pressure p_Z is less than half the inlet pressure $p_U/2$, valve V2 is leaking.

If pressure p_Z is greater than half the inlet pressure $p_U/2$, valve V2 is tight. Valve V2 is opened for the set opening time t_L . V2 closes again.

During the measurement time t_M , the tightness control checks the pressure p_Z between the valves.

If pressure p_Z is greater than half the inlet pressure $p_U/2$, valve V1 is leaking.

If pressure p_Z is less than half the inlet pressure $p_U/2$, valve V1 is tight.

The tightness test can only be performed if pressure p_d downstream of V2 is around atmospheric pressure.

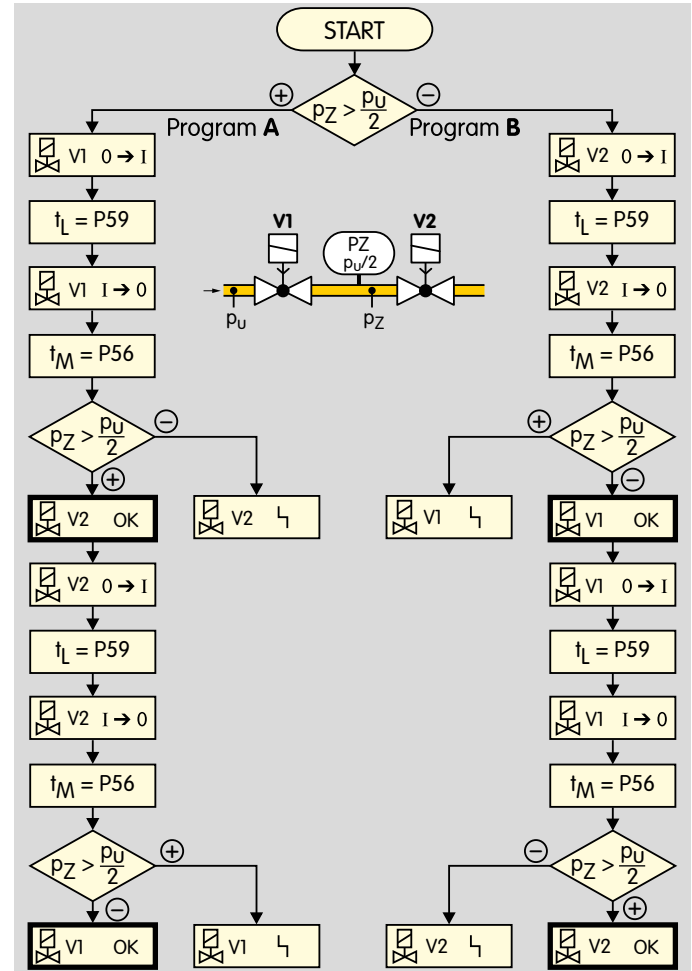

5 Valve proving system

Program B

Valve V2 opens for the set opening time t_L . V2 closes again. During the measurement time t_M , the tightness control checks the pressure p_Z between the valves.

If pressure $p_Z > p_U/2$, valve V1 is leaking.

If pressure $p_Z < p_U/2$, valve V1 is tight. Valve V1 is opened for the set opening time t_L . V1 closes again.

During the measurement time t_M , the tightness control checks the pressure p_Z between the valves.

If pressure $p_Z < p_U/2$, valve V2 is leaking.

If pressure $p_Z > p_U/2$, valve V2 is tight.

The tightness test can only be performed if pressure p_d downstream of V2 is around atmospheric pressure.

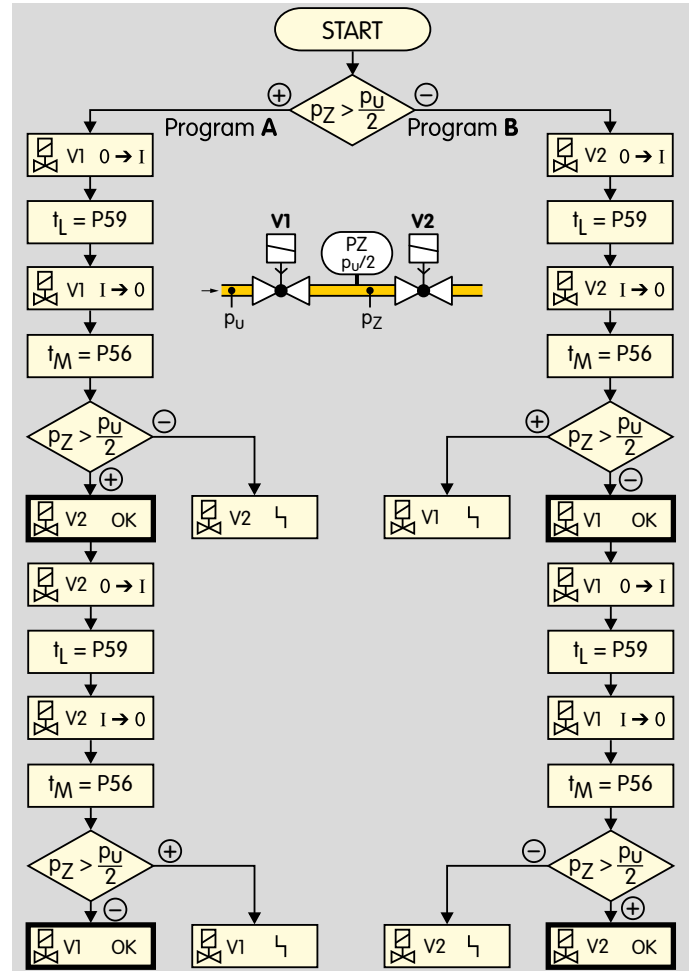

5.2 Test period t_p

Depending on the burner capacity, the tightness of the gas solenoid valves must be checked in accordance with the relevant application standard, e.g. EN 676, EN 746, NF-PA 85 and NFPA 86.

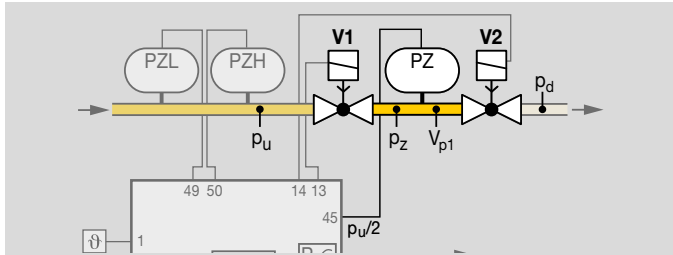

The test period t_p is calculated from:

- Opening times t_L for V1 and V2,
- Measurement times t_M for V1 and V2.

$$t_p \text{ [s]} = 2 \times t_L + 2 \times t_M$$

5 Valve proving system

5.2.1 Extended valve opening time t_L

Standard EN 1643:2000 allows a maximum opening time of 3 s for the tightness test if the main gas valves are actuated directly. If the gas can flow into the combustion chamber when a valve is opened, the gas volume must not exceed 0.05% of the maximum flow rate.

If the preset opening time $t_L = 3$ s is inadequate (e.g. if slow opening motorized valves VK are used) to build up or reduce the test volume pressure, bypass valves with an extended opening time may be used (e.g. VAS 1 or bypass valves with an additional orifice). Parameter 52 = 4 must be selected for this.

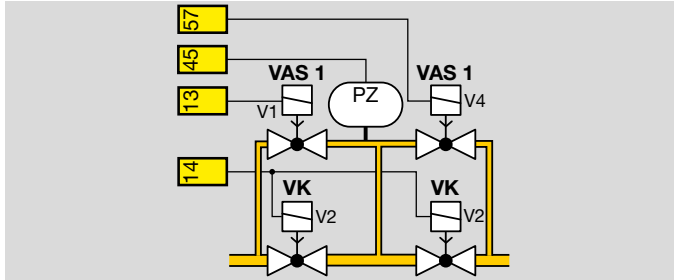

Calculation example

Nominal flow rate $Q_{(N)}$:

P (kW): capacity = 1000 kW

H_u (kWh/m³): lower heating value of gas type = 10 kWh/m³

$$Q_N \text{ (m}^3\text{/h)} = \frac{P \text{ (kW)}}{H_u \text{ (kWh/m}^3\text{)}}$$

$$Q_N \text{ (m}^3\text{/h)} = \frac{1000 \text{ kW}}{10 \text{ kWh/m}^3} = 100 \text{ m}^3\text{/h}$$

Max. gas volume in combustion chamber V_O :

$$V_O \text{ (l/h)} = Q_N \times 0.05\%$$

$Q_{(N)}$ (m³/h): nominal flow rate = 100 m³/h (100,000 l/h)

$$V_O \text{ (l/h)} = 100000 \text{ l/h} \times 0.05\% = 50 \text{ l/h}$$

Required opening time t_L :

$$t_L \text{ (s)} = \frac{400 \times V_O}{\pi \times d^2 \times 0.7} \times \sqrt{\frac{\rho}{2 \times p_u}}$$

V_O (l/h): max. gas volume in combustion chamber = 50 l/h,

d (mm): orifice diameter of bypass valve = 9.45 mm,

flow factor = 0.7,

p_u (mbar): inlet pressure = 20 mbar,

ρ (kg/m³): density of gas = 0.8 kg/m³

$$t_L \text{ (s)} = \frac{400 \times 50 \text{ l/h}}{3.14 \times 9.45^2 \times 0.7} \times \sqrt{\frac{0.8 \text{ kg/m}^3}{2 \times 20 \text{ mbar}}} = 14.26 \text{ s}$$

Enter the next lowest value for parameter 59 (P59 = 14) to set the opening time, see page 84 (10.7.4 Valve opening time 1 tL1).

Calculating the extended valve opening time

Calculation module for calculating the opening time t_L , see www.adlatus.org, Extended valve opening time

- » The calculation module can be used to calculate the opening time t_L for the bypass valves (e.g. VAS 1 or bypass valves with additional orifice) by entering the gas type, heating value, density, capacity, inlet pressure and orifice diameter.
- » Set the next lowest value for parameter 59 to set the opening time, see page 84 (10.7.4 Valve opening time 1 tL1).

5.2.2 Measurement time t_M

The sensitivity of the tightness control in the BCU can be adjusted for each individual system by adapting the measurement time t_M . The longer the measurement time t_M , the greater the sensitivity of the tightness control. The measurement time is set using parameter 56 to a value between 3 and 3600 s – see page 84 (10.7.3 Measurement time for Vp1).

The required measurement time t_M is calculated from:
Inlet pressure p_u [mbar]
Leakage rate Q_L [l/h]
Test volume $V_{p1} + V_{p2}$ [l]
Calculation of the test volume – see “Test volume V_{p1} ”

For one test volume V_{p1} (between 2 gas solenoid valves)

Adjustable using parameter 56

$$t_M [s] = \left(\frac{2 \times p_u \times V_{p1}}{Q_L} \right)$$

For a large test volume V_{p1} with reduced testing time

Adjustable using parameter 56

$$t_M [s] = \left(\frac{0.9 \times p_u \times V_{p1}}{Q_L} \right)$$

Conversion into US units – see page 108 (17 Converting units)

Leakage rate

The BCU tightness control makes it possible to check a specific leakage rate Q_L . Within the European Union, the maximum leakage rate Q_L is 0.1% of the maximum flow rate Q_{max} . [m^3/h].

$$Q_L [l/h] = \frac{Q_{max.} (m^3/h) \times 1000 [l/h]}{1000 \times 1 (m^3/h)}$$

5 Valve proving system

Test volume V_{p1}

Test volume V_{p1} is calculated from the valve volume V_V , added to the volume of the pipe V_R for each additional metre in length L .

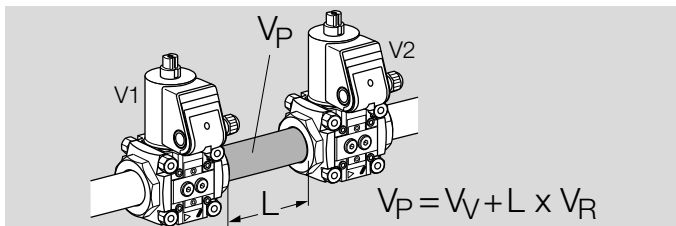

The measurement time required for test volumes V_{p1} and V_{p2} must be set on the basis of the calculation using parameter 56.

Valves		Pipe	
Type	Volume V_V [l]	DN	Volume per metre V_R [l/m]
VAS 1	0.08	10	0.1
VAS 2	0.32	15	0.2
VAS 3	0.68	20	0.3
VAS 6	1.37	25	0.5
VAS 7	2.04	40	1.3
VAS 8	3.34	50	2
VAS 9	5.41	65	3.3
VG 10	0.01	80	5
VG 15	0.07	100	7.9
VG 20	0.12	125	12.3
VG 25	0.2	150	17.7
VG 40/VK 40	0.7	200	31.4
VG 50/VK 50	1.2	250	49
VG 65/VK 65	2		
VG 80/VK 80	4		
VK 100	8.3		
VK 125	13.6		
VK 150	20		
VK 200	42		
VK 250	66		

Calculation examples

2 valves VAS 665,

distance $L = 9.5$ m,

inlet pressure $p_u = 50$ mbar,

max. flow rate $Q_{\max.} = 200$ m³/h.

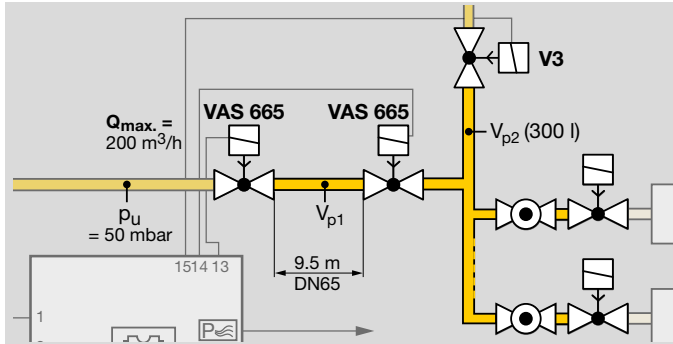

Measurement time for one test volume V_{p1}

$$t_M [s] = \left(\frac{2 \times 50 \text{ mbar} \times 32.45 \text{ l}}{200 \text{ l/h}} \right) = 16.23 \text{ s}$$

» Set the next highest value (17 s) using parameter 56.

The measurement time can be set to a value between 3 and 3600 s in steps of 1 s.

5.3 Proof of closure function

For applications in the territory covered by NFPA 85 and 86.

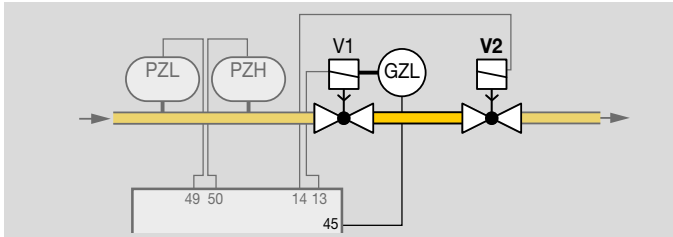

The proof of closure function monitors the function of the gas solenoid valve V1. The proof of closure function can be activated by setting parameter 51 = 4, see page 83 (10.7.1 Valve proving system).

A limit switch on gas solenoid valve V1 signals the closed position of the valve to the BCU (terminal 45).

5.3.1 Program sequence

When the start-up signal is received at terminal 1, the BCU checks that valve V1 is in its closed position using the POC switch. If a signal is not received at terminal 45 from the POC switch after a timeout time of 10 s (valve V1 is closed), the BCU performs a fault lock-out with fault message c1.

As soon as the BCU has opened valve V1, it queries the open position of the valve via the POC switch. If a signal is still being received at terminal 45 from the POC switch after a timeout time of 10 s, the BCU performs a fault lock-out with fault message c8.

6 BCSOft

BCSoft is an engineering tool for PCs with a Windows operating system. BCSOft (from version 3.1x or 4.x.x) makes it possible to set device parameters in order to adjust them to the specific application. BCSOft logs and archives the device parameters. In addition, BCSOft offers further functions. In conjunction with Manual mode, the process values overview provides commissioning support in order to facilitate the commissioning process. In the event of faults or service interventions, details on troubleshooting can be derived from the device statistics and the fault history.



The current versions of the engineering tools BCSOft3 and BCSOft4 are available at www.docuthek.com.

In addition to the engineering tool BCSOft, an opto-adapter with USB connection is required for data transfer between the PC and BCU. If the burner control unit BCU is operated in conjunction with the bus module BCM 500, communication via Ethernet is possible. In this case, BCSOft 4.x.x is required.

BCSOft4 and opto-adapter PCO 200, see page 95 (13 Accessories).

7 Fieldbus communication

PROFINET and Modbus TCP are manufacturer-independent, open standards for Industrial Ethernet. They cover the requirements for automation technology (manufacturing automation, process automation, drive applications without functional safety).

PROFINET and Modbus TCP are bus variants for fieldbus communication, optimized for speed and low connection costs.

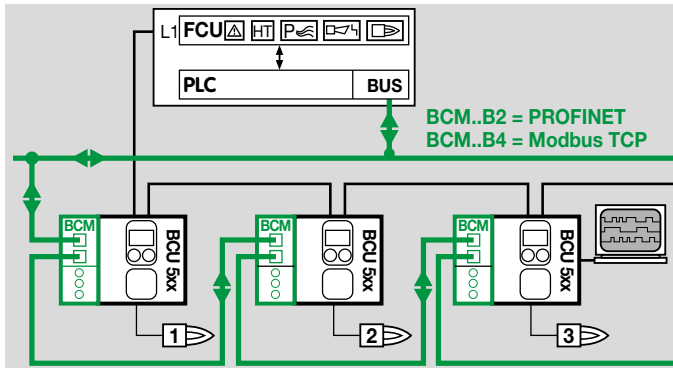

The basic function of PROFINET and Modbus TCP is the exchange of process and required data between a controller (e.g. PLC) and several distributed devices (e.g. BCM with BCU/FCU).

The signals from the devices are read into the controller cyclically. There, they are processed and are then output to the devices again.

7.1 BCU 570 and bus module BCM

The optional bus module BCM 500 is required to integrate the BCU 570 in a fieldbus system (PROFINET IO or Modbus TCP).

Control signals (for start, reset and air actuator control, for example), signal states from the device inputs and outputs and information about the device status (operating states, flame signal and current program step, for example), warnings and faults can be transferred simultaneously via the bus module between the BCU 570 and PLC.

Bus module BCM 500 has two RJ45 connection sockets for connection to the fieldbus on its front. The connection sockets are combined with an internal 2-port switch. This allows the BCM 500 together with the BCU 570 to be integrated in various network topologies (star, tree or line topology). Requirements such as Auto Negotiation and Auto Crossover are satisfied.



Safety-related signals and interlocks (e.g. safety interlock) must be wired independently of the fieldbus communication direct between the burner control unit (e.g. BCU) and the protective system (e.g. FCU).

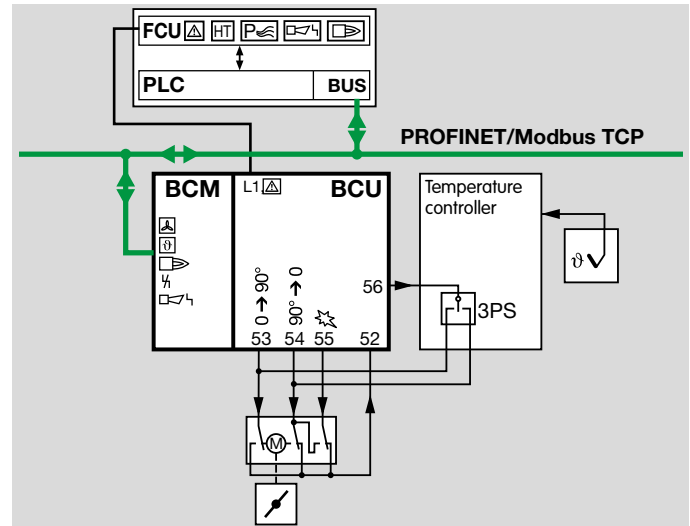

All network components which connect the automation system and the field devices must be certified for the relevant fieldbus use.

For information on planning and the structure of a network and the components to be used (e.g. cables, lines and switches)

for PROFINET and PROFIBUS, see www.profinet.com,
for Modbus TCP, see www.modbus.org.

7.2 Configuration, planning

Before commissioning, the bus module must be configured for data exchange with the fieldbus system using an engineering tool or BCSOft.

To do so:

- 1 bus module BCM must be connected to the device (BCU 570),
- 2 fieldbus communication must be enabled on the device (BCU 570),
- 3 the code switches on the BCM must be set, see also page 89 (10.10.7 Fieldbus communication).

7.2.1 Device master data file (GSD)

The technical properties of a device are described by the manufacturer in a device master data file (GSD file). The GSD file is required for integration of the device (BCU/FCU) in the configuration of the PLC. The GSD file contains the device image, the communications properties and all fault messages from the device in text form which are important for the configuration of the PROFINET network and the data exchange. Modules defined in the GSD file may be selected for configuration to integrate the device. The GSD file for the bus module can be ordered at www.docuthek.com. The steps required to integrate the file are described in the instructions for the engineering tool for your automation system.

7.2.2 Modbus TCP

The Modbus protocol is a communications protocol based on a Client/Server architecture. Once the TCP/IP connection between client (PLC) and server (BCU/FCU) has been established, useful data can be transferred via this connection as often and in as great an amount as required. The

PLC and BCU/FCU can establish up to 3 parallel TCP/IP connections at the same time. Using the function codes 3, 6 and 16, data can be transferred to and from the BCU/FCU. The PLC must send output data to the BCU/FCU at least every 125 ms in order to ensure data transfer and functioning of the BCU/FCU. If the output data is missing or sent too late, the bus module will interpret them as "0".

7.2.3 Modules/Registers for process data

All modules (PROFINET) and registers (Modbus TCP) required for data exchange between the PLC and the burner control unit BCU 570 are shown in the following table.

Module (PROFINET) Register (Modbus TCP)	PROF-INET slot	Modbus address	Address	Operation
Outputs	1	0	n	w
Inputs	1	6 ¹⁾	n...n+1	r
Flame signal 1	2	9	n	r
Status signals	3	12	n	r
Fault and warning signals	4	15	n...n+1	r
Remaining times	5	18	n	r
TC remaining times ²⁾	6	21	n...n+1	r
PLC output terminal information	7	24	n	r
BCU input terminal information	8	27	n...n+1	r
BCU output terminal information	9	30	n...n+1	r

¹⁾ Modbus TCP: see table "Modbus TCP – register structure".

²⁾ Only for BCU..C1. Slot 7/address 24 is not transferred with other device versions.

Modbus TCP – register structure

Example of "Inputs" register:

Modbus address	6		7	
Format	Word		Word	
PLC address byte	Byte n .7 .0	Byte n+1 .7 .0	Byte n+2 .7 .0	Byte n+3 .7 .0

Inputs/Outputs

The digital input and output signals of the burner control unit BCU 570 are included in this module/register.

Input bytes (BCU → PLC)

The input bytes describe the digital signals which are transferred from the BCU to the digital inputs of the PLC. The digital signals take up 3 bytes (24 bits).

Bit	Byte n	Byte n+1	Format
0	Burner 1 operating signal	Max. capacity reached ¹⁾	BOOL
1	Free	Min. capacity reached ¹⁾	BOOL
2	BCU system fault	Free	BOOL
3	Fault lock-out	Free	BOOL
4	Safety shut-down	Free	BOOL
5	Warning	Free	BOOL
6	ON	Free	BOOL
7	Manual mode	Burner 1 flame signal	BOOL

¹⁾ Only with three-point step control via bus.

Output byte (PLC → BCU)

The output byte describes the digital signals which are output by the PLC to the BCU. The digital signals to control the burner control unit BCU 570 occupy 1 byte (8 bits).

Parallel to the bus communication, terminals 1 to 3 of the BCU can be wired. This allows the BCU to be controlled using the digital signals of the bus communication or the inputs at the terminals.

Bit	Byte n	Format
0	Reset ¹⁾	BOOL
1	Burner 1 start ¹⁾	BOOL
2	External air ON ¹⁾	BOOL
3	Free	BOOL
4	Free	BOOL
5	Free	BOOL
6	Open control element, three-point step Open ²⁾	BOOL
7	Close control element, three-point step Close ²⁾	BOOL

¹⁾ Parallel to the bus communication, terminals 1 to 3 can be wired.

²⁾ Only with three-point step control via bus.

Burner 1 flame signal (BCU → PLC)

The flame signal for burner 1 is transferred from the BCU to the PLC as an analogue value using this module/register. The flame signal occupies one byte with values from 0 to 255 (= flame signal from 0 to 25.5 μ A).

Bit	Byte n	Data type	Format	Value
0	Burner 1 flame signal	Byte	DEC	0–255 ¹⁾
1				
2				
3				
4				
5				
6				
7				

¹⁾ See code table “GSD Codes BCU 570” or “Modbus Profile BCU 570” at www.docuthek.com.

Status signals (BCU → PLC)

This module/register transfers the status signals from the BCU to the PLC. The status signals occupy one byte (0 to 255). Every status signal is allocated a code. The allocation is described in the code table “GSD Codes BCU 570”.

Bit	Byte n	Data type	Format	Value
0	Status signals	Byte	DEC	0–255 ¹⁾
1				
2				
3				
4				
5				
6				
7				

¹⁾ See code table “GSD Codes BCU 570” or “Modbus Profile BCU 570” at www.docuthek.com.

Bit	Byte n+1	Data type	Format	Value
0	Warning signals	Byte	DEC	0–255 ¹⁾
1				
2				
3				
4				
5				
6				
7				

¹⁾ See code table “GSD Codes BCU 570” or “Modbus Profile BCU 570” at www.docuthek.com.

Fault and warning signals (BCU → PLC)

The fault and warning signals are transferred from the BCU to the PLC using this module/register. The fault and warning signals occupy one byte each (0 to 255).

The same allocation table applies to the fault signals and the warning signals.

Bit	Byte n	Byte n+1	Data type	Format	Value
0	Fault signals		Word	DEC	0–255 ¹⁾
1					
2					
3					
4					
5					
6					
7					

Bit	Byte n	Byte n+1	Data type	Format	Value
0	Warning signals		Word	DEC	0–255 ¹⁾
1					
2					
3					
4					
5					
6					
7					

¹⁾ See code table “GSD Codes BCU 570” or “Modbus Profile BCU 570” at www.docuthek.com.

Remaining times (BCU → PLC)

This module/register transfers the remaining times of various processes from the BCU to the PLC. The remaining time occupies 2 bytes.

Bit	Byte n	Byte n+1	Data type	Format	Value
0	Remaining times		Word	DEC	0–6554 (0 to 6554 s)
1					
2					
3					
4					
5					
6					
7					

Remaining times of the valve proving system (BCU → PLC)

Only with BCU..C1.

The module/register in BCU..C0 contains no information.

This module/register transfers the remaining time of the valve proving system system from the BCU..C1 to the PLC. The remaining time occupies 2 bytes.

The valve check runs parallel to other time-related processes, e.g. pre-purge. To display the remaining time of the valve proving system separately, it is transferred separately.

Bit	Byte n	Byte n+1	Data type	Format	Value
0	Remaining times of the valve proving system		Word	DEC	0–6554 (0 to 6554 s)
1					
2					
3					
4					
5					
6					
7					

PLC output information (BCU → PLC)

This module/register transfers information on signals which the PLC uses to control the BCU back to the PLC. This allows the signal transfer from the PLC to the BCU to be checked.

Bit	Byte n	Format
0	Reset	BOOL
1	Burner 1 start	BOOL
2	External air ON	BOOL
3	Free	BOOL
4	Free	BOOL
5	Free	BOOL
6	Open control element, three-point step Open ¹⁾	BOOL
7	Close control element, three-point step Close ¹⁾	BOOL

¹⁾ Only with three-point step control via bus.

BCU input terminal information (BCU → PLC)

This module/register transfers the signal states of the digital inputs on the BCU (input terminals) to the PLC.

Bit	Byte n	Byte n+1	Format
0	Terminal 1	Terminal 50	BOOL
1	Terminal 2	Terminal 51	BOOL
2	Terminal 3	Terminal 52	BOOL
3	Terminal 45	Terminal 65	BOOL
4	Terminal 46	Terminal 66	BOOL
5	Terminal 47	Terminal 67	BOOL
6	Terminal 48	Terminal 68	BOOL
7	Terminal 49	Free	BOOL

BCU output terminal information (BCU → PLC)

This module/register transfers the signal states of the digital outputs on the BCU (output terminals) to the PLC.

Bit	Byte n	Byte n+1	Format
0	Terminal 9	Terminal 55	BOOL
1	Terminal 13	Terminal 56	BOOL
2	Terminal 14	Terminal 57	BOOL
3	Terminal 15	Terminal 58	BOOL
4	Terminal 17/18	Free	BOOL
5	Terminal 37/38	Free	BOOL
6	Terminal 53 ¹⁾	Free	BOOL
7	Terminal 54	Free	BOOL

¹⁾ Only for BCU..F2: terminal 53 is used as an input. Bit 2 has no function.

7.2.4 Device parameters and statistics

PROFINET

With the help of acyclic communication between the PLC and BCU, it is possible to read information on parameters, statistics and fault history on an event basis (e.g. using system function block Siemens FSB 52 RDREC).

Index	Description
1001	Parameters
1002	Device statistics, counter
1003	Device statistics, faults/warnings
1004	Operator statistics, counter
1005	Operator statistics, faults/warnings
1006	Fault history
1007	Power module statistics

The available data records differ in terms of their indexes. The contents and description of the indexes are described in the code table “GSD Codes BCU 570” (download from www.docuthek.com).

Modbus TCP

Address	Description
256–511	Parameters
512–767	Device statistics, counter
768–1023	Device statistics, faults/warnings
1024–1279	Operator statistics, counter
1280–1535	Operator statistics, faults/warnings
1536–1791	Fault history
1792–2047	Power module statistics

The available data records differ in terms of their addresses. The contents and description of the addresses are described in the code table “Modbus Profile BCU 570” (download from www.docuthek.com).

8 Program step/status

DISPLAY ¹⁾	Program step/status
00	Start-up position/Standby
H0	Delay
01	Fan run-up time t_{GV}
d 0	"No flow" state check of low air pressure protection device
d 1	Low air pressure protection check
Rc	Approaching minimum capacity/closed position ²⁾
Ro	Approaching maximum capacity
P1	Pre-purge
Ri	Approaching ignition capacity
H2	Delay
tc	Valve check
03	Pre-ignition time t_{VZ}
04	Safety time 1 t_{SA1}
05	Flame proving period 1 t_{FS1}
06	Safety time 2 t_{SA2}
07	Flame proving period 2 t_{FS2}
H8	Delay
08	Operation/controller enable
09	Over-run up to minimum capacity
P9	Post-purge
C1	Controlled air flow
UH	Remote control with OCU
	Data transfer (programming mode)
--	Device Off

¹⁾ In Manual mode, four dots flash on the display.

9 Fault messages

Fault message (flashing)	DISPLAY	Description
Flame simulation	01	Flame simulation/Flame signal before ignition
No flame after safety time 1	04	No flame formation to end of 1 st safety time
Flame failure during flame proving period 1 t_{FS1}	05	
Flame failure during safety time 2 t_{SA2}	06	No flame formation to end of 2 nd safety time
Flame failure during flame proving period 2 t_{FS2}	07	
Flame failure during operation	08	
Too many remote resets	10 ¹⁾	Remote reset activated > 5 × in 15 min.
Too many restarts	11	> 5 restarts in 15 minutes
Controller enable output (terminal 56)	20 ¹⁾	Controller enable output incorrectly connected
Simultaneous activation (terminals 51 and 52)	21 ¹⁾	“Maximum capacity” and “Ignition capacity” position feedback from butterfly valve set simultaneously
Actuator wiring (terminals 52–55)	22	Faulty wiring of terminals 52–55
Actuator feedback (terminal 52)	23 ¹⁾	Maximum or ignition capacity is not constantly signalled back to terminal 52
Simultaneous Min./Max. bus command	24 ¹⁾	“Open actuator” and “Close actuator” bus signals set simultaneously
Non-fail-safe parameters (NFS) inconsistent	30 ¹⁾	NFS parameter range is inconsistent
Fail-safe parameters (FS) inconsistent	31 ¹⁾	FS parameter range is inconsistent
Mains voltage	32 ¹⁾	Operating voltage too high/low
Faulty parameterization	33 ¹⁾	Parameter set contains illegal settings
Incompatible bus module	35	
Power module defective	36 ¹⁾	Relay contact fault caused by defective relay contacts, EMC influence, by applying voltage to outputs or by an incorrect load module
Inlet valve(s) leaking	40	Leak found on inlet valve
Outlet valve(s) leaking	41	Leak found on outlet valve
Pressure switch/gas valve wiring	44	Test volume (V_{p1} or V_{p2}) cannot be supplied or vented; faulty pressure switch/gas valve wiring
Controller enable/Emergency stop	50 ³⁾	No signal at the controller enable/emergency stop input
Fuse defective	51 ¹⁾	
Permanent remote reset	52 ¹⁾	Remote reset input activated > 25 s
Timing cycle too short	53	Minimum timing cycle not observed
Internal error	80 ¹⁾	Flame amplifier error/Device error
Internal error	89 ¹⁾	Error in processing internal data

9 Fault messages

Fault message (flashing)	DISPLAY	Description
Internal error	94 ¹⁾	Error at digital inputs
Internal error	95 ¹⁾	Error at digital outputs
Internal error	96 ¹⁾	Error when checking the SFR
No PCC, power module error	97 ¹⁾	Error when reading the EEPROM
Internal error	98 ¹⁾	Error when writing to the EEPROM
emBoss	99 ¹⁾	Shut-down without application error
Minimum capacity not reached	Rc	Position for minimum capacity has not been reached after 255 s
Maximum capacity not reached	Ro	Position for maximum capacity has not been reached after 255 s
Ignition capacity not reached	Ri	Position for ignition capacity has not been reached after 255 s
Communication with bus module	b E ¹⁾	Bus module fault
Parameter chip card (PCC)	CC ¹⁾	Incorrect or defective PCC
POC valve open	c I	No input signal for closed valve
POC valve closed	c B	Valve not open
Air monitor "no flow" state	d G	Fault Air monitor "no flow" state check. The signal from the pressure switches is received at terminal 36 or 37 before the air actuator is opened.
Low air pressure (display d1, d2, d3, d4, d5, d6, d7, d8 or d9)	d I to d 9	No input signal from pressure switch or failure in air supply during program step 1, 2, 3, 4, 5, 6, 7, 8 or 9
Air flow during pre-purge	d P	Air flow failure during pre-purge
Waiting for connection	n G ²⁾	BCU waiting for connection to controller
Invalid address	n I ²⁾	Invalid or incorrect address set on bus module
Invalid configuration	n Z ²⁾	The bus module has received an incorrect configuration from the controller
Invalid network name	n 3 ²⁾	Invalid network name or no address allocated in the network name
Controller in STOP position	n 4 ²⁾	Controller in STOP position
High gas pressure (display o0, o1, o2, o3, o4, o5, o6, o7, o8 or o9)	o I to o 9 ³⁾	No input signal from pressure switch at terminal 50 during program step 0, 1, 2, 3, 4, 5, 6, 7, 8 or 9
Low gas pressure (display u1, u2, u3, u4, u5, u6, u7, u8 or u9)	u I to u 9 ³⁾	No input signal from pressure switch at terminal 49 during program step 1, 2, 3, 4, 5, 6, 7, 8 or 9

¹⁾ System faults can only be acknowledged using the Reset/Information button on the BCU.

²⁾ The BCU shows a warning message on the display. The BCU can continue to be operated via the control inputs.

³⁾ If fault lock-out has been programmed, the fault must be acknowledged using the Reset/Information button. If safety shut-down has been programmed, no fault signal is sent via the fault signalling contact. As soon as the fault no longer exists, the fault message on the display disappears. Acknowledging the fault using the Reset/Information button is not necessary.

10 Parameter

Any changes to parameters will be saved to the parameter chip card.

Name	Parameter	Value range	Factory default settings
page 52 (10.2.1 Burner 1 flame signal FS1 switch-off threshold)	01	2–20 = Burner 1 flame signal switch-off threshold in μA (depending on P04)	2–20 μA where P04 = 0 5–20 μA where P04 = 1 5 μA where P04 = 2
page 52 (10.2.2 Flame control)	04	0 = Flame rod 1 = UVS sensor 2 = UVC sensor	0
page 53 (10.3.1 Burner 1 start-up attempts)	07	1 = 1 start-up attempt 2 = 2 start-up attempts 3 = 3 start-up attempts	1
page 60 (10.4.1 Restart)	09	0 = Off 1 = Burner 1 4 = Max. 5 x in 15 min. for burner 1	0
page 63 (10.5.1 Emergency stop)	10	0 = Off 1 = With safety shut-down 2 = With fault lock-out	2
page 63 (10.5.2 High gas pressure protection)	12	0 = Off 1 = With safety shut-down 2 = With fault lock-out	2
page 64 (10.5.3 Low gas pressure protection)	13	0 = Off 1 = With safety shut-down 2 = With fault lock-out	2
page 64 (10.5.4 Low air pressure protection)	15	0 = Off 1 = With safety shut-down 2 = With fault lock-out	2
page 65 (10.5.5 Safety time during operation tSB)	19	1; 2 = Time in seconds	1
page 66 (10.6.1 Fan run-up time tGV)	30	0–6000 = Time in seconds	0
page 66 (10.6.2 Air monitoring during controlled air flow)	32	0 = Off; maximum capacity 1 = On; maximum capacity 2 = Off; controller enable	1
page 54 (10.3.2 Start-up with pre-purge after controlled shut-down within 24 hours)	33	0 = On (depending on P34 Pre-purge time t_{PV}) 1 = Off; no air control 2 = Off; start from position for ignition capacity 3 = Off; start from minimum capacity/closed position 4 = Off; start from position for minimum capacity	0

10 Parameter

Name	Parameter	Value range	Factory default settings
page 66 (10.6.3 Pre-purge time tPV)	34	0–6000 = Time in seconds	6000
page 67 (10.6.4 Air flow monitoring during pre-purge)	35	0 = Off 1 = With safety shut-down 2 = With fault lock-out	2
page 67 (10.6.5 Post-purge time tPN)	37	0–6000 = Time in seconds	6000
page 67 (10.6.6 Air flow monitoring during post-purge)	38	0 = On; control element to maximum capacity 1 = Off; control element to maximum capacity 2 = Off; control element to ignition capacity 3 = Off; control element controller enable	1
page 68 (10.6.7 Capacity control)	40	0 = Off 1 = With IC 20 2 = With IC 40 3 = With RBW 4 = With frequency converter	BCU..F1 = 1 BCU..F2 = 3
page 76 (10.6.8 Running time selection)	41	0 = Off; checking the positions for minimum/maximum capacity 1 = On; for approaching the positions for minimum/maximum capacity 2 = On; for approaching the position for maximum capacity 3 = On; for approaching the position for minimum capacity	0
page 76 (10.6.9 Running time)	42	0–250 = Running time in seconds, if parameter 41 = 1, 2 or 3	30
page 77 (10.6.10 Low fire over-run)	43	0 = Off 1 = Up to minimum capacity	0
page 77 (10.6.11 Controller enable signal delay time tRF)	44	0–250 = Time in seconds	0
page 83 (10.7.1 Valve proving system)	51	0 = Off 1 = Tightness test before start-up 2 = Tightness test after shut-down 3 = Tightness test before start-up and after shut-down 4 = Proof of closure function	0
page 83 (10.7.2 Relief valve (VPS))	52	2 = V2 3 = V3 4 = V4	2
page 84 (10.7.3 Measurement time for Vp1)	56	3 = Time in seconds 5–25 = (in 5 s steps) 30–3600 = (in 10 s steps)	10
page 84 (10.7.4 Valve opening time 1 tL1)	59	2–25 = Time in seconds	2
page 62 (10.4.2 Minimum operating time tB)	61	0–250 = Time in seconds	0
page 85 (10.8.1 Minimum pause time tMP)	62	0–3600 = Time in seconds	0
page 85 (10.8.2 Switch-on delay time tE)	63	0–250 = Time in seconds	0

Name	Parameter	Value range	Factory default settings
page 86 (10.9.1 Operating time in Manual mode)	67	0 = Unlimited 1 = 5 minutes	1
page 87 (10.10.1 Function of terminal 51)	69	0 = Off 1 = Feedback of position for maximum capacity (IC 40/RBW) 2 = AND with emergency stop (trm. 46) 3 = AND with air min. (trm. 47) 4 = AND with air flow monitoring (trm. 48) 5 = AND with gas min. (trm. 49) 6 = AND with gas max. (trm. 50)	0
page 87 (10.10.2 Function of terminal 65)	70	0 = Off 1 = Reduced DG test duration 2 = AND with emergency stop (trm. 46) 3 = AND with air min. (trm. 47) 4 = AND with air flow monitoring (trm. 48) 5 = AND with gas min. (trm. 49) 6 = AND with gas max. (trm. 50)	0
page 88 (10.10.3 Function of terminal 66)	71	0 = Off 1 = FCU as zone control unit 2 = External HT signal 3 = AND with emergency stop (trm. 46) 4 = AND with air min. (trm. 47) 5 = AND with air flow monitoring (trm. 48) 6 = AND with gas min. (trm. 49) 7 = AND with gas max. (trm. 50)	0
page 88 (10.10.4 Function of terminal 67)	72	0 = Off 1 = BCU ready; if not, safety shut-down 2 = BCU ready; if not, fault lock-out 3 = AND with emergency stop (trm. 46) 4 = AND with air min. (trm. 47) 5 = AND with air flow monitoring (trm. 48) 6 = AND with gas min. (trm. 49) 7 = AND with gas max. (trm. 50)	0
page 88 (10.10.5 Function of terminal 68)	73	0 = Off 1 = Contactor feedback 2 = AND with emergency stop (trm. 46) 3 = AND with air min. (trm. 47) 4 = AND with air flow monitoring (trm. 48) 5 = AND with gas min. (trm. 49) 6 = AND with gas max. (trm. 50)	0

Name	Parameter	Value range	Factory default settings
page 78 (10.6.12 Capacity control (bus))	75	0 = Off 1 = MIN. to MAX. capacity; standby in position for MIN. capacity 2 = MIN. to MAX. capacity; standby in CLOSED position 3 = IGNITION to MAX. capacity; standby in CLOSED position 4 = MIN. to MAX. capacity; standby in position for MIN. capacity; burner quick start 5 = IGNITION to MAX. capacity; standby in CLOSED position; burner quick start	0
page 89 (10.10.6 Password)	77	0000–9999 = Four-digit number code	1234
page 55 (10.3.3 Burner application)	78	0 = Burner 1 1 = Burner 1 with pilot gas 2 = Burner 1 and burner 2 3 = Burner 1 and burner 2 with pilot gas	0
page 62 (10.4.3 Pilot burner)	79	0 = With shut-down 1 = In continuous operation	0
page 89 (10.10.7 Fieldbus communication)	80	0 = Off 1 = With address check 2 = No address check	1
page 57 (10.3.4 Pre-ignition time tVZ)	93	0–5 = Time in seconds	1
page 58 (10.3.5 Safety time 1 tSA1)	94	2, 3, 5, 10 = Time in seconds	5
page 58 (10.3.6 Flame proving period 1 tFS1)	95	0–20 = Time in seconds	2
page 59 (10.3.7 Safety time 2 tSA2)	96	2, 3, 5, 10 = Time in seconds	3
page 59 (10.3.8 Flame proving period 2 tFS2)	97	0–20 = Time in seconds	2

10.1 Scanning the parameters

During operation, the 7-segment display shows the program step/status.

All the parameters of the BCU 570 can be scanned in numerical order by repeatedly pressing the Reset/Information button (for 1 s).

The parameter display is ended 60 seconds after the last time the button is pressed or by switching off the BCU 570.

The BCU 570 displays -- when the mains switch is off. The parameters cannot be scanned when the BCU 570 is switched off or when a fault message is displayed.

10.2 Flame control

The BCU is fitted with a flame amplifier which evaluates whether an adequate flame signal is supplied by the burner using a flame rod or UV sensor.

10.2.1 Burner 1 flame signal FS1 switch-off threshold

Parameter 01

The sensitivity at which the burner control unit detects a flame can be set using parameter 01.

As soon as the measured flame signal falls below the set value (2 to 20 μ A), the BCU performs a fault lock-out during start-up after the elapse of the safety time or during operation after the elapse of the safety time during operation (parameter 19).

In the case of UV control, this value can be increased, should the burner to be monitored be influenced by other burners, for example.

10.2.2 Flame control

Parameter 04

Parameter 04 = 0: flame control is performed with a flame rod.

Parameter 04 = 1: flame control is performed with a UV sensor for intermittent operation (UVS). To meet the normative requirements for intermittent operation, the burner is shut down and restarted automatically after a continuous operating time of 24 hours. This shut-down and subsequent restart are performed in the same way as a normal controlled shut-down. Depending on the parameterization, the burner is started with or without pre-purge. This process is controlled independently by the BCU and therefore it must be checked whether the industrial process permits the pause in heat supply it creates.

Parameter 04 = 2: flame control is performed with a UV sensor for continuous operation (UVC).

The response times of the BCU and UV sensor for continuous operation are coordinated so that the set safety time during operation (parameter 19) is not extended.

10.3 Behaviour during start-up

10.3.1 Burner 1 start-up attempts

Parameter 07

This parameter defines the maximum number of possible start-up attempts of the burner.

Taking into account national standards and requirements, it must be clarified whether multiple start-up attempts are permitted.

If no flame is detected during start-up, an immediate fault lock-out ($P07 = 1$) or up to two additional start-up attempts ($P07 = 2, 3$) are performed depending on parameter 07.

Parameter 07 = 1: 1 start-up attempt. If no flame is formed during the start-up, so that at the end of the safety time t_{SA1} or t_{SA2} no flame signal is detected, this will result in a BCU safety shut-down with subsequent fault lock-out. The fault message **04** or **05** will flash in the BCU display, depending on the burner operating mode.

Parameter 07 = 2, 3: 2 or 3 start-up attempts. If no flame is formed during the start-up, so that at the end of the safety time t_{SA1} no flame signal is detected, the BCU closes the gas valves and repeats the start-up. Each start-up attempt begins with the parameterized start-up behaviour.

If safety time t_{SA1} or t_{SA2} elapses without a flame signal having been detected, even after the last parameterized start-up attempt, this will result in a BCU safety shut-down with subsequent fault lock-out. The fault message **04** or **05** will flash in the BCU display, depending on the burner operating mode.

If the parameters for the limits of high gas pressure protection (P12), low gas pressure protection (P13), low air pressure protection (P15) or air flow monitoring during pre-

purge (P35) are set to safety shut-down (P12, P13, P15 or P35 = 1) and there is no signal at the input for the relevant limit (terminal 47, 48, 49 or 50), depending on parameter 07 an immediate fault lock-out ($P07 = 1$) or up to two additional start-up attempts ($P07 = 2, 3$) will take place.

10.3.2 Start-up with pre-purge after controlled shut-down within 24 hours

Parameter 33

Parameter 33 determines whether the BCU activates pre-purge after a controlled shut-down before a fresh burner start and in what position the actuator stays during standby. The requirement for this is that the last controlled shut-down took place within the last 24 hours.

If parameter 33 = 1, 2 or 3, pre-purge is not required for a start-up after a controlled shut-down within the last 24 hours. After switching on the BCU (mains on), after a safety shut-down or fault lock-out and after a controlled shut-down more than 24 hours previously, the BCU will always perform a pre-purge.

Parameter 33 = 0: On (depending on P34 Pre-purge time t_{PV}). The BCU starts a pre-purge for every start-up for the time set in parameter 34.

Parameter 33 = 1: Off; no air control. No control element is connected to the BCU (parameter 40 = 0). Pre-purge is deactivated.

Parameter 33 = 2: Off; start from position for ignition capacity. If the start-up takes place within 24 hours of the last controlled shut-down, pre-purge is suppressed. The actuator is in the position for ignition capacity during standby (after a controlled shut-down).

Parameter 33 = 3: Off; start from minimum capacity/closed position. If the start-up takes place within 24 hours of the last controlled shut-down, pre-purge is suppressed. The actuator is in the position for minimum capacity during standby (after a controlled shut-down).

Starting up without pre-purge (quick start, P33 = 1, 2, 3) prevents air flowing into the combustion chamber unnecessarily. This accelerates the burner start-up.

Taking into account national standards and requirements, it must be clarified whether the quick start option without pre-purge may be used.

10.3.3 Burner application

Parameter 78

This parameter enables the BCU to be adjusted to various burner applications. In principle, a distinction is made between applications with one burner ($P78 = 0$) and applications with a burner and pilot burner ($P78 = 2$). In both applications, an optional pilot gas valve (V3) can be parameterized via which the burner is started with a defined ignition capacity.

Parameter 78 = 0: burner 1. Two valves (V1, V2) are included for a modulating, directly ignited burner. These are connected to the valve outputs (terminals 13 and 14). Valves V1 and V2 are opened in parallel to start the burner in order to release the gas supply to the burner.

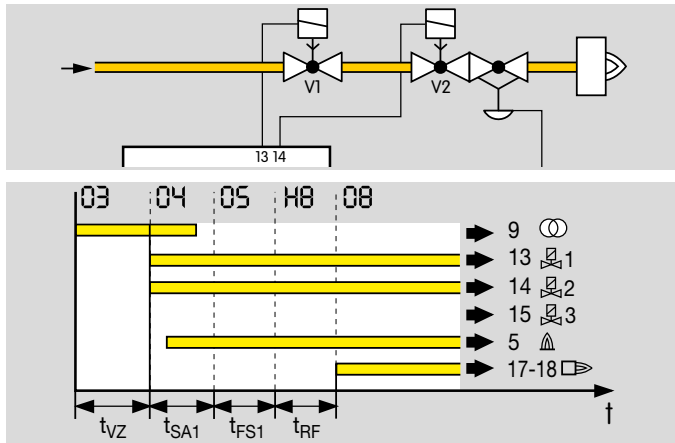

Parameter 78 = 1: burner 1 with pilot gas. Three valves (V1, V2 and V3) are included for a modulating, directly ignited burner with a pilot gas valve. These are connected to the valve outputs (terminals 13, 14 and 15). Valves V1 and V3 open to start the burner. The burner is started with a limited ignition capacity using gas valve V3. After the elapse of the safety time t_{SA1} (program step 04), valve V2 opens. Valve V3 is closed again after the elapse of the flame proving period t_{FS1} (program step 05).

For this application, it must be ensured that the flame proving period (P95) is set to a value ≥ 2 s.

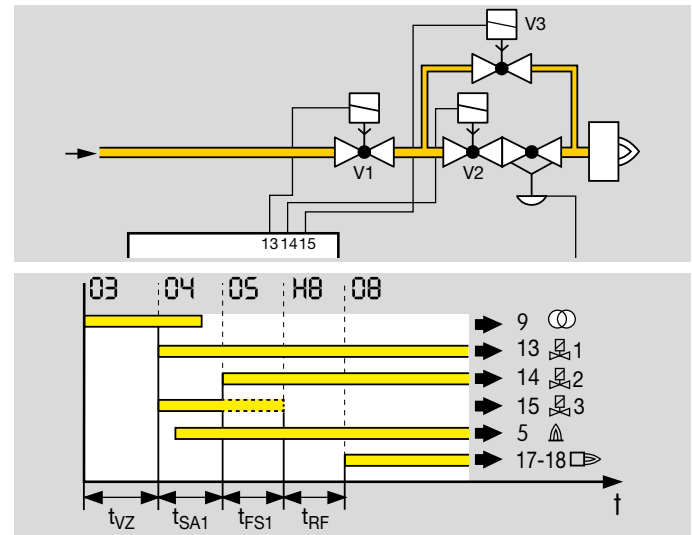

10 Parameter

Parameter 78 = 2: burner 1 and burner 2. Three valves (V1, V2 and V4) are included for a modulating burner with a pilot burner. These are connected to the valve outputs (terminals 13, 14 and 57). Valves V1 and V4 open to start the pilot burner. Gas valve V2 releases the gas supply to the main burner. Gas valve V2 releases the gas supply to the main burner.

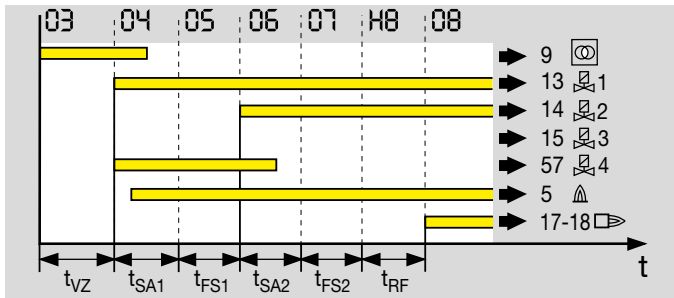
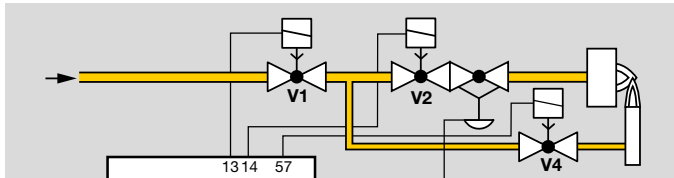

Parameter 78 = 3: burner 1 and burner 2 with pilot gas. In this application, the burner has an additional pilot gas valve V3. The valves are connected to the valve outputs (terminals 13, 14, 15 and 57). Valves V1 and V4 open to start the pilot burner. The burner is started with a limited ignition capacity using gas valve V3. After the elapse of the safety time t_{SA2} (program step 06), valve V2 opens (terminal 14). Valve V3 is closed again after the elapse of the flame proving period t_{FS2} (program step 07).

For this application, it must be ensured that the flame proving period (P97) is set to a value ≥ 2 s.

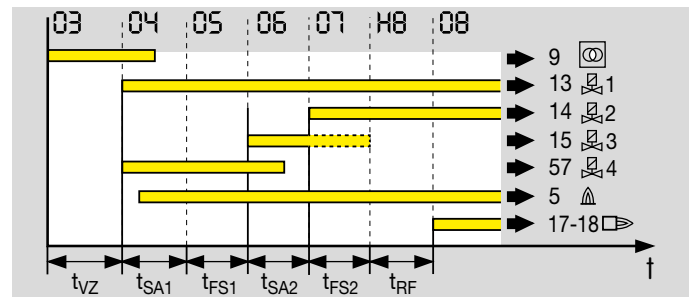
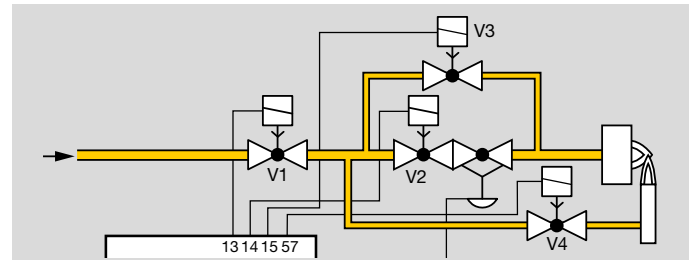

10.3.4 Pre-ignition time t_{vz}

Parameter 93

The ignition is activated at the start of the pre-ignition time (0 to 5 s). The valves are closed during the pre-ignition time. The ignition spark can stabilize in the air flow. Only after the pre-ignition time has ended will the valves be opened to ignite the flame. The safety time on start-up is started after the end of the pre-ignition time.

10.3.5 Safety time 1 t_{SA1}

Parameter 94

During safety time 1 t_{SA1} , the flame (pilot flame) is ignited. It can be set to 2, 3, 5 or 10 s.

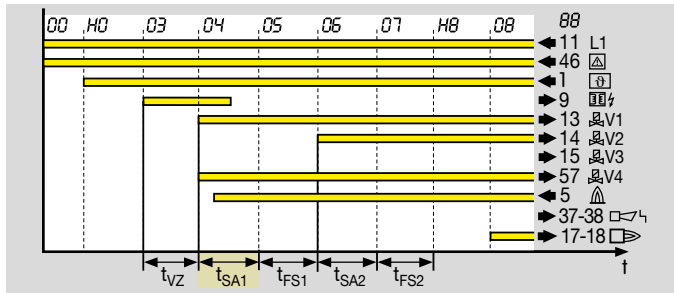

Safety time 1 is then started after the end of the pre-ignition time t_{VZ} . Valves V1 and V4 open at the start of safety time 1. The fuel supply to burner 1 (pilot burner) is released so that a flame can form. If no flame is detected at the end of safety time 1, the valves are closed again. Depending on parameter 07 (Burner 1 start-up attempts), the BCU reacts either with an immediate safety shut-down with fault lock-out (P07 = 1) or with up to two additional start-up attempts (P07 = 2 or 3). The BCU will complete a maximum of three start-up attempts.

Safety time 1 must be determined on the basis of current national standards and regulations. The burner application and the burner capacity are the main criteria for this.

If the start-up signal (terminal 1) or the Gas_{min} signal (terminal 49) drops out during safety time 1, the valves will not be switched off until the end of safety time 1.

10.3.6 Flame proving period 1 t_{FS1}

Parameter 95

Flame proving period 1 (t_{FS1}) can be parameterized to enable the flame on burner 1 to stabilize after the elapse of safety time 1. Only when the flame proving period has elapsed will the next program steps be initiated by the BCU. The flame proving period can be set to between 0 and 20 s.

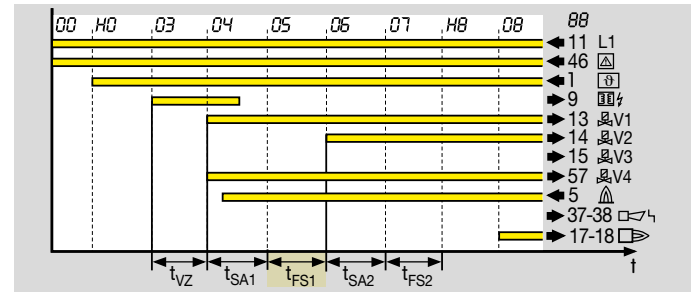

If parameter 78 = 1 has been selected (burner with pilot gas), flame proving period 1 will automatically be set to min. 2 s.

10.3.7 Safety time 2 t_{SA2}

Parameter 96

During safety time 2 t_{SA2} , the flame on burner 2 (main flame) is ignited. It can be set to 2, 3, 5 or 10 s.

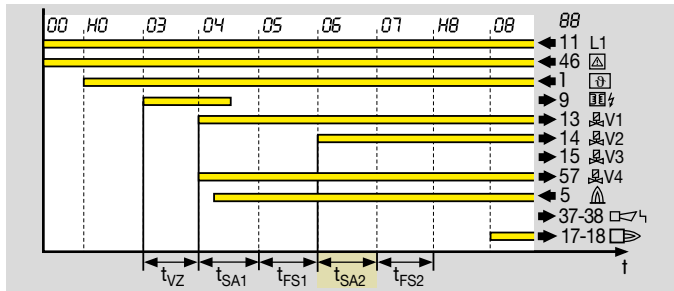

Valve V2 opens at the start of safety time 2. The fuel supply to burner 2 is released so that a flame can form. If no flame is detected at the end of safety time 2, the valves are closed again. Depending on parameter 09 (Burner 2 start-up attempts), the BCU reacts either with an immediate safety shut-down with fault lock-out ($P09 = 1$) or with up to two additional start-up attempts ($P09 = 2$ or 3). The BCU will complete a maximum of three start-up attempts.

Safety time 2 must be determined on the basis of current national standards and regulations. The burner application and the burner capacity are the main criteria for this.

If the signals for start-up (terminal 1) or Gas_{min} . (terminal 49) drop out during safety time 2, the valves will not be switched off until the end of safety time 2.

10.3.8 Flame proving period 2 t_{FS2}

Parameter 97

Flame proving period 2 t_{FS2} can be parameterized to enable the flame on burner 2 to stabilize after the elapse of safety

time 2. Only when the flame proving period has elapsed will the next program steps be initiated by the BCU. The flame proving period can be set to between 0 and 20 s.

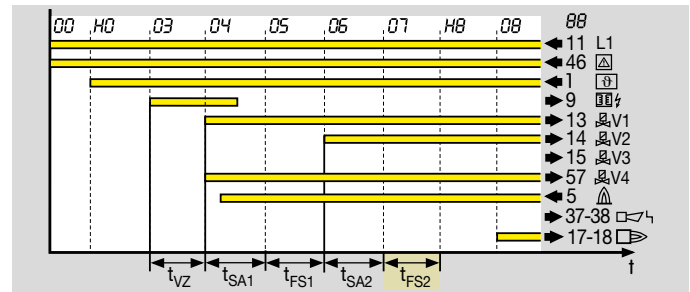

If parameter 78 (Burner application) = 3 has been selected (burner with pilot gas), flame proving period 2 (t_{FS2}) will automatically be set to min. 2 s.

10.4 Behaviour during operation

10.4.1 Restart

Parameter 09

Restart can be programmed for burners which occasionally display unstable behaviour during operation.

This parameter determines whether the BCU initiates an immediate fault lock-out or an automatic restart after a safety shut-down during operation. Excessive restarts, however, can be detected.

Taking into account national standards and requirements, it must be clarified whether the restart function may be used.

In the event of a restart after a safety shut-down, post-purge occurs if a post-purge time (P37) has been programmed. Then the combustion air fan is switched off and the program sequence starts from the start-up position (display 00).

Parameter 09 = 0: Off.

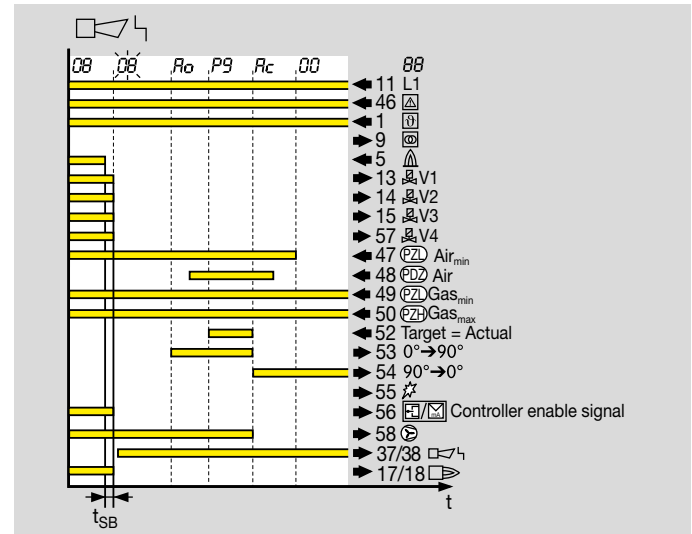

A safety shut-down with subsequent fault lock-out takes place in the event of flame failure during operation. Post-purge occurs if a post-purge time has been programmed.

Parameter 09 = 1: burner 1. The restart function is active.

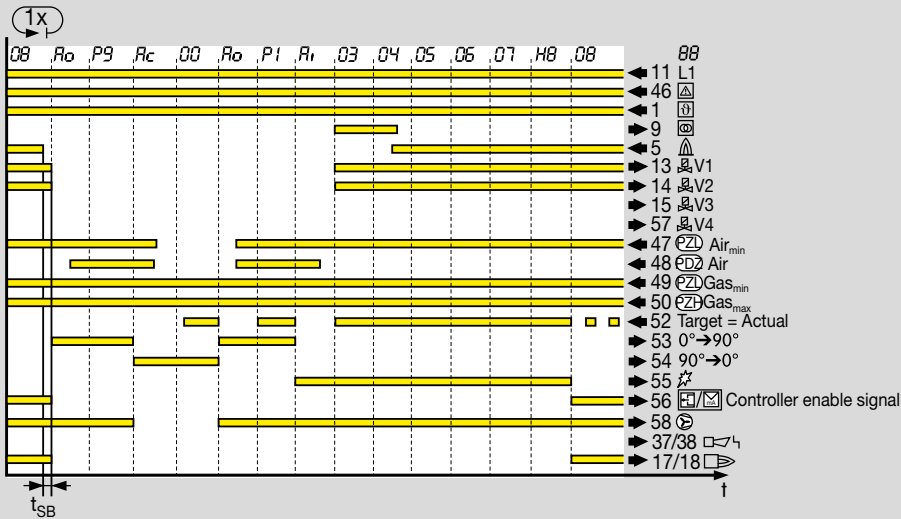

If a safety shut-down occurs during operation (minimum operating time of 2 s), the valves are closed and the operation signalling contact is opened within the safety time during operation t_{SB} . Post-purge occurs if a post-purge time has been programmed. The burner control unit then attempts to restart the burner once. If the burner does not function, a safety shut-down with fault lock-out occurs. The display blinks and shows the fault message.

Parameter 09 = 4: max. 5 × in 15 min. for burner 1. The restart function is active and is also monitored for excessive restarts.

In certain conditions, it is possible that the restart function is repeated continuously without a safety shut-down with subsequent fault lock-out being performed. The BCU has a safety shut-down with subsequent fault lock-out option

if more than 5 restarts are performed within a period of 15 minutes.

10.4.2 Minimum operating time t_B

Parameter 61

A minimum operating time (0 to 250 s) may be defined to ensure that the heating equipment operates stably.

If the minimum operating time is active, burner operation will be maintained until the set time has elapsed even if the start-up signal fails.

The minimum operating time starts as soon as the program step for operation/controller enable (display 08) has been reached.

If the start-up signal drops out before the start of operation/controller enable, e.g. during pre-purge, the burner control unit reverts directly to the start-up position (standby) and the burner is not ignited.

The minimum operating time is cancelled when the BCU is switched off or the mains voltage supply interrupted, or if a safety shut-down occurs.

10.4.3 Pilot burner

Parameter 79

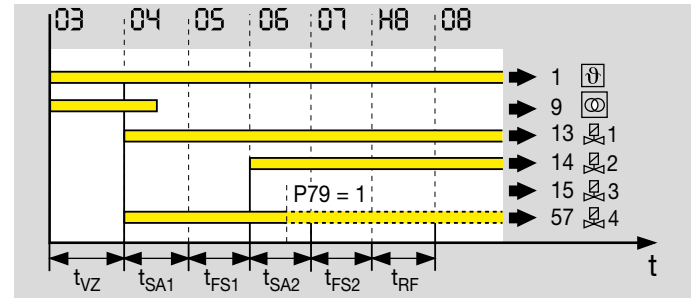

If a burner with a pilot burner is used, this parameter can be used to define whether the pilot burner is shut down 1 second before the end of the second safety time t_{SA2} or operates continuously.

Parameter 79 = 0: with shut-down.

Parameter 79 = 1: in continuous operation.

Taking into account national standards and requirements, it must be clarified whether the pilot burner can remain in operation permanently. Special requirements for the type of burner must be satisfied for this purpose.

10.5 Safety limits

Parameters 10, 12, 13, 15 and 19 can be used to adjust the safety limits (emergency stop, high gas pressure protection, low gas pressure protection, air monitoring and safety time during operation) to the system requirements.

10.5.1 Emergency stop

Parameter 10

Function and properties of the controller enable/emergency stop input (terminal 46)

This input is the safety interlock input of the BCU. Activation of this input and the shut-down properties can be set using parameter 10. If the signal is interrupted when the safety interlock input on terminal 46 is active, the BCU initiates a function depending on parameter 10.

Parameter 10 = 0: Off; the function of the safety interlock input is deactivated.

Parameter 10 = 1: On; a safety shut-down will be performed if there is no signal at the controller enable/emergency stop input (terminal 46).

Parameter 10 = 2: On; a fault lock-out will be performed if there is no signal at the controller enable/emergency stop input (terminal 46).

10.5.2 High gas pressure protection

Parameter 12

Function of the gas_{max.} input (terminal 50)

The maximum gas pressure is monitored permanently using the gas_{max.} gas pressure switch connected to terminal 50. Activation of the high gas pressure protection device and the shut-down properties can be set using parameter 12. If the gas pressure exceeds the value set on the gas_{max.} pressure switch, the signal to terminal 50 is interrupted and the BCU initiates a function depending on parameter 12.

Parameter 12 = 0: Off; the high gas pressure protection function is deactivated.

Parameter 12 = 1: On; a safety shut-down will be performed if there is no signal at the gas_{max.} input (terminal 50).

Parameter 12 = 2: On; a fault lock-out will be performed if there is no signal at the gas_{max.} input (terminal 50).

10.5.3 Low gas pressure protection

Parameter 13

Function of the gas_{min} input (terminal 49)

The minimum admissible gas pressure is ensured by the gas_{min} gas pressure switch connected to terminal 49 when the start-up signal (terminal 1) is applied. Activation of the low gas pressure protection device and the shut-down properties can be set using parameter 13. If the gas pressure falls below the value set on the gas_{min} pressure switch, the signal to terminal 49 is interrupted and the BCU initiates a function depending on parameter 13.

Parameter 13 = 0: Off; the low gas pressure protection function is deactivated.

Parameter 13 = 1: On; a safety shut-down will be performed if there is no signal at the gas_{min} input (terminal 49).

Parameter 13 = 2: On; a fault lock-out will be performed if there is no signal at the gas_{min} input (terminal 49).

10.5.4 Low air pressure protection

Parameter 15

The minimum air pressure is ensured by the air_{min} air pressure switch connected to terminal 47 while the combustion air supply (terminal 58) is switched on. Activation of the low air pressure protection device and the shut-down properties can be set using parameter 15.

If the air pressure falls below the value set on the air_{min} air pressure switch, the signal to terminal 47 is interrupted and the BCU initiates a function depending on parameter 15.

When the combustion air supply (terminal 58) is switched off, the “no flow” state (default position) of the air pressure switch (PZL) is checked. In systems where the combustion air supply is not controlled by the BCU, the air supply to the

pressure switch can be interrupted by a 2/3-way valve. The 2/3-way valve is actuated by terminal 58.

Parameter 15 = 0: Off; the low air pressure protection function is deactivated.

Parameter 15 = 1: with safety shut-down. If there is no signal at the air_{min} input (terminal 47), a safety shut-down will be performed.

Parameter 15 = 2: with fault lock-out. If there is no signal at the air_{min} input (terminal 47), a fault lock-out will be performed.

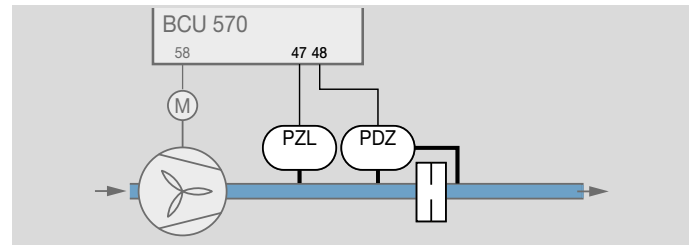

If air flow monitoring is active ($P35 = 1$ or 2), the “no flow” state of the air flow monitoring pressure switch (PDZ) is also checked.

For further information on the low air pressure protection function (air_{min} , terminal 47, and air flow, terminal 48) during pre-purge, see page 67 (10.6.4 Air flow monitoring during pre-purge).

10.5.5 Safety time during operation t_{SB}

Parameter 19

Parameter 19 = 1; 2: time in seconds

The safety time during operation is the time that the BCU needs to stop the fuel supply after a flame failure during operation or an interruption at the safety limit inputs (terminals 45 to 51 and 65 to 68). The safety time can be set to 1 or 2 s. Prolonging the safety time during operation increases the tolerance with respect to brief-duration signal fades (e.g. fades of the flame signal).

In accordance with EN 298, the maximum flame failure response time must not exceed 1 s unless specific application standards allow other values.

Under EN 746-2, the safety time of the installation during operation (total closing time) must not exceed 3 s unless specific application standards allow other values.

The requirements of national standards and regulations must be satisfied.

10.6 Air control

10.6.1 Fan run-up time t_{GV}

Parameter 30

This parameter defines the time between the activation of the fan (terminal 58) and the start of the BCU program sequence (display \bar{t}).

The fan run-up time can be parameterized in a range between 0 and 6000 s.

10.6.2 Air monitoring during controlled air flow

Parameter 32

Controlled air flow is activated by actuating the input (terminal 2). The connected fan (terminal 58) is switched on. Parameter 32 can be used to adjust the behaviour of the actuator during controlled air flow. It also decides whether the low air pressure protection device (PZL) and the air flow (PDZ) should be monitored during controlled air flow.

Parameter 32 = 0: Off; maximum capacity.

The actuator is moved to the position for maximum capacity during controlled air flow. Monitoring of the low air pressure protection device (PZL) and the air flow (PDZ) is not active.

Parameter 32 = 1: On; maximum capacity.

The actuator is moved to the position for maximum capacity during controlled air flow. Monitoring of the low air pressure protection device (PZL) and the air flow (PDZ) is active. The display on the BCU shows $P\bar{t}$ (Pre-purge). The controlled air flow time is subtracted from the pre-purge time of a subsequent burner start.

Parameter 32 = 2: Off; controller enable.

The controller enable signal (terminal 56) is issued during controlled air flow. The position of the actuator can be

changed using an external temperature controller (controlled cooling). Monitoring of the low air pressure protection device (PZL) and the air flow (PDZ) is not active.

10.6.3 Pre-purge time t_{PV}

Parameter 34

A burner start may only occur if it has been ensured that the concentration of inflammable components in all sections of the combustion chamber and the connected areas as well as the flue gas ducts is less than 25% of the lower flammability limit of the fuel gas. A pre-purge is generally performed to ensure compliance with these requirements.

Parameter 34 is used to parameterize the pre-purge time in a range between 0 and 6000 s.

The pre-purge time t_{PV} is to be set on the basis of the relevant application standard (e.g. EN 676, EN 746-2, NFPA 85 or NFPA 86).

If air monitoring has been activated in parameter 15 or 35, the pre-purge time t_{PV} starts as soon as the air flow monitor detects an adequate flow for purging, see page 64 (10.5.4 Low air pressure protection) and page 67 (10.6.4 Air flow monitoring during pre-purge).

10.6.4 Air flow monitoring during pre-purge

Parameter 35

Function of the air flow_{min.} input (terminal 48)

The air flow is monitored during pre-purge by the sensor (differential pressure switch) connected to terminal 48. If the air volume falls below the value set on the sensor, the BCU will perform a safety shut-down or fault lock-out.

When the fan is switched off, the “no flow” state (default position) of the air flow monitoring sensor is also checked if air flow monitoring has been activated. Activation of air flow monitoring and the shut-down properties can be set using parameter 35.

Parameter 35 = 0: Off; the air flow monitoring function is deactivated.

Parameter 35 = 1: with safety shut-down. If the air flow monitor (terminal 48) trips, a safety shut-down will be performed.

Parameter 35 = 2: with fault lock-out. If there is no signal at the input (terminal 48), a fault lock-out will be performed.

Air flow monitoring is to be set on the basis of the relevant application standard (e.g. EN 676, EN 746-2, NFPA 85 or NFPA 86).

10.6.5 Post-purge time t_{PN}

Parameter 37

If a post-purge time has been set, this will start immediately after the end of the burner operation. This allows the combustion chamber and the flue gas routes to be ventilated to remove fuel gas residues. Parameter 37 is used to parameterize the post-purge time in a range between 0 and 6000 s.

If the post-purge time has been activated, other settings are required for low air pressure protection, see page 9

(1.1.3 Modulating-controlled forced draught burner with pilot burner and valve proving system).

10.6.6 Air flow monitoring during post-purge

Parameter 38

Parameter 38 is used to define whether the air flow is monitored and which position the actuator assumes during post-purge. Air flow monitoring can only be selected if low air pressure protection (parameter 15 = 1, 2) is active.

Parameter 38 = 0: On; control element to maximum capacity. The actuator is moved to the position for maximum capacity during the post-purge time. The air flow is monitored.

Parameter 38 = 1: Off; control element to maximum capacity. The actuator is moved to the position for maximum capacity during the post-purge time. The air flow is not monitored.

Parameter 38 = 2: Off; control element to ignition capacity. The actuator is moved to the position for ignition capacity during the post-purge time. If the position of the actuator at this time is less than the position for ignition capacity, this position is not changed. The air flow is not monitored.

Parameter 38 = 3: Off; control element controller enable. The controller enable signal (terminal 56) is issued. The position of the actuator can be changed using an external temperature controller (controlled cooling). The air flow is not monitored.

10.6.7 Capacity control

Parameter 40

BCU..F1 and BCU..F2 are fitted with an interface for connecting air actuators.

They activate a control element or frequency converter via the outputs for capacity control (terminals 53 to 56) for purging, cooling or starting the burners. The air actuator moves to the required position for the relevant operating situation.

Using parameter 40, you can set which actuator is used for capacity control.

Capacity control via bus, see page 78 (10.6.12 Capacity control (bus)).

Parameter 40 = 0: Off; no capacity control (no air actuator).

Parameter 40 = 1: with IC 20.

The interface is configured to the requirements of actuators IC 20, IC 20..E, IC 50 or IC 50..E.

Alternatively, comparable three-point step actuators may be used.

IC 20

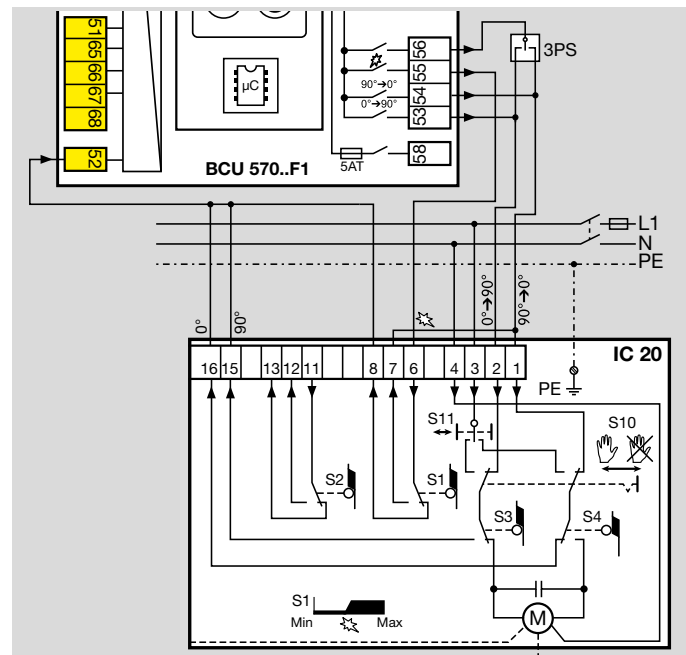

The positions for maximum capacity, ignition capacity and minimum capacity can be set using the actuator. It is checked whether the relevant position has been reached using terminal 52. If the position is not reached within the timeout time of 255 s, the BCU will display fault message **Rc**, **Ro** or **Ri** (minimum, maximum or ignition capacity not reached), see page 46 (9 Fault messages).

In the event of a fault, the actuator is moved to the position set via cam S4 for minimum capacity via the output at terminal 54.

Control range between the positions for minimum and maximum capacity

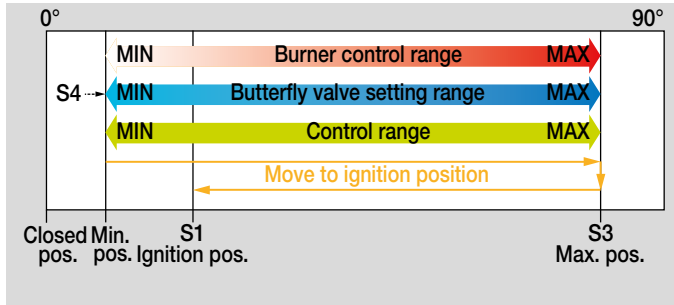

The control system is enabled for operation via the controller enable output (terminal 56). During the controller enable procedure, the actuator can be adjusted infinitely between the positions for maximum and minimum capacity by an external three-point step controller. There is no timeout active in this case.

Control range between the positions for maximum capacity and ignition capacity

The wiring between the BCU and the 3-point step controller can be adjusted so that the control range of the actuator is between the positions for maximum and ignition capacity.

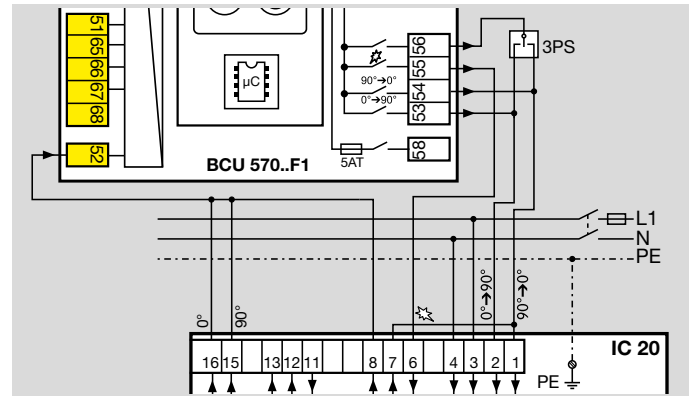

The minimum position which can be reached is the closed position.

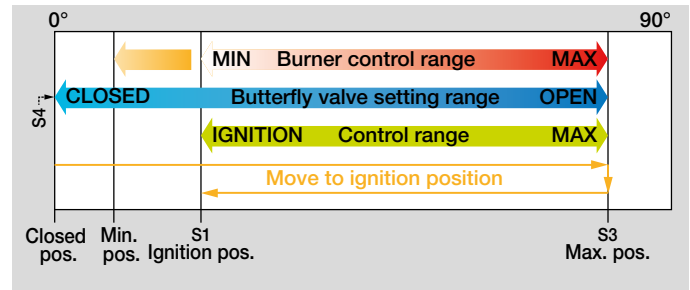

Manual mode

In Manual mode, the actuator can be moved between the positions for maximum and minimum capacity in 3-point step operation. No timeout is active when approaching these positions. The controller enable output (terminal 56) is not active and not checked.

IC 20..E

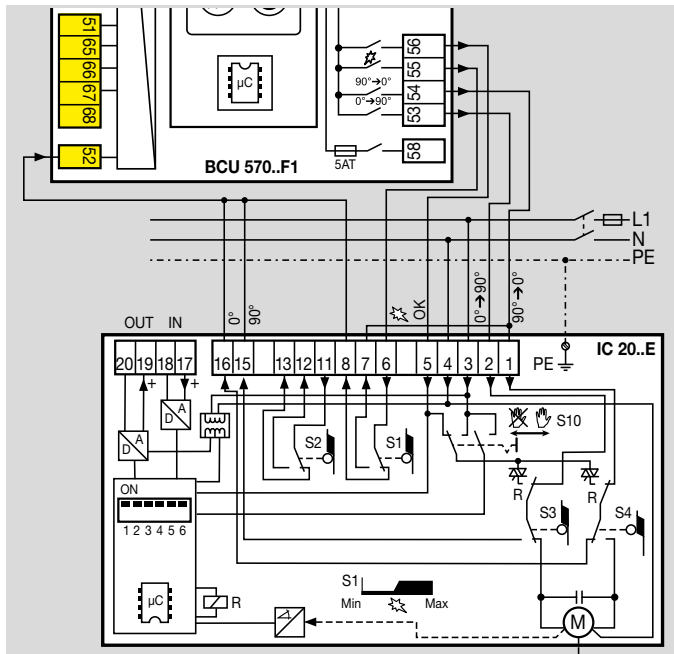

The positions for minimum capacity, maximum capacity and ignition capacity can be set using the actuator. When the appropriate position has been reached, this information is signalled back via terminal 52.

If no signal is received that the position has been reached within the timeout time of 255 s, a fault lock-out of the BCU will be performed and a fault message (*Rc*, *Ro* or *Ri*) will be displayed, see page 46 (9 Fault messages).

Control range between the positions for minimum and maximum capacity

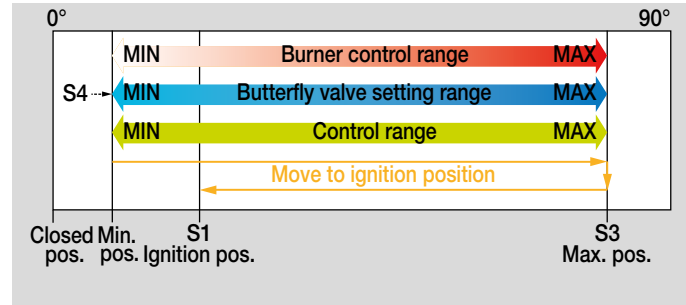

The control system is enabled during operation via the controller enable output (terminal 56). During the controller enable procedure, the actuator can be adjusted infinitely between the positions for maximum and minimum capacity using its analogue input (terminals 17 and 18). There is no timeout active in this case.

Manual mode

In Manual mode, the actuator can be moved between the positions for maximum and minimum capacity in 3-point step operation. No timeout is active when approaching these positions. The controller enable output (terminal 56) is not active and not checked.

IC 40

Parameter 40 = 2: with IC 40.

The interface is configured according to the requirements of actuator IC 40 with an optional analogue input.

» **Operating mode 27 must be parameterized on the IC 40 to ensure communication with the BCU.**

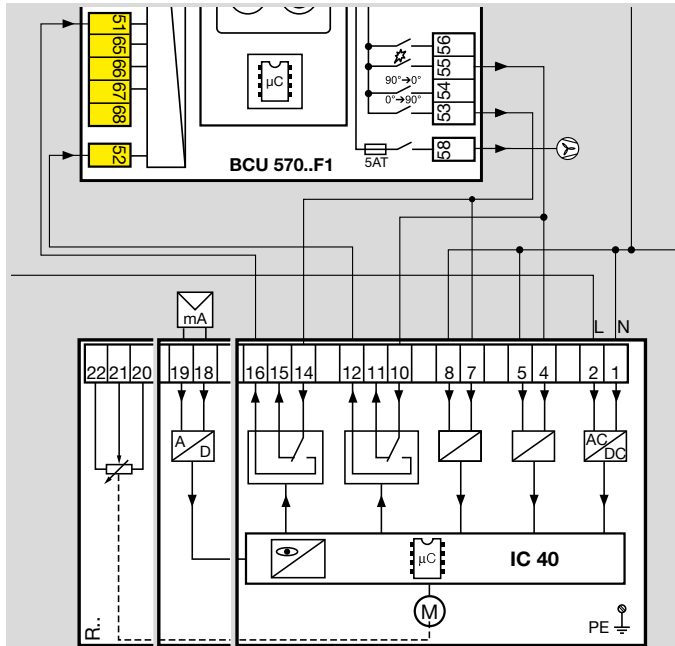

The positions for maximum capacity and ignition capacity can be set using the actuator. Terminal 51 checks whether the position for maximum capacity has been reached. Terminal 52 checks the position for ignition capacity. If the position is not reached within the timeout time of 255 s, a fault lock-out of the BCU will be performed. A fault mes-

sage (Rc , Ro or Ri) will be displayed, see page 46 (9 Fault messages).

If a controller enable is active, the control system is enabled for operation via the outputs at terminals 53 and 55.

During the controller enable procedure, the actuator IC 40 can be adjusted infinitely between the positions for maximum and minimum capacity using its analogue input (terminals 18 and 19). There is no timeout active in this case.

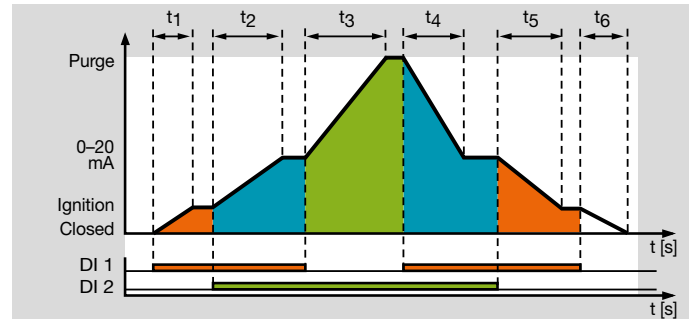

BCU		IC 40	
Signal at terminal	Position	Butterfly valve position	
55	53		
Off	Off	Closed	Closed
On	Off	Ignition	Minimum/ignition capacity
On	On	0–20 mA	Any position between minimum and maximum capacity
Off	On	Open	Maximum capacity

In the event of a fault, there will be no signal at terminals 53 and 55 so that the actuator moves to the closed position. When approaching the closed position, no timeout of 255 s is active since no feedback input is checked. This may result in a situation where the program is continued in the case of a request for the closed position, without the

butterfly valve being closed. The outputs at terminals 56 (controller enable) and 54 (closed position) on the BCU are non-functional and are not activated.

Manual mode

In Manual mode, no external controller is enabled. The actuator can be moved to the positions for maximum capacity or ignition capacity by the user. 3-point step operation is not possible. No timeout is active when approaching these positions.

RBW

Parameter 40 = 3: with RBW

The actuator can be moved to the positions for maximum capacity (contact COM to HI) and minimum capacity (contact COM to LO) using the interface and by closing the various contacts.

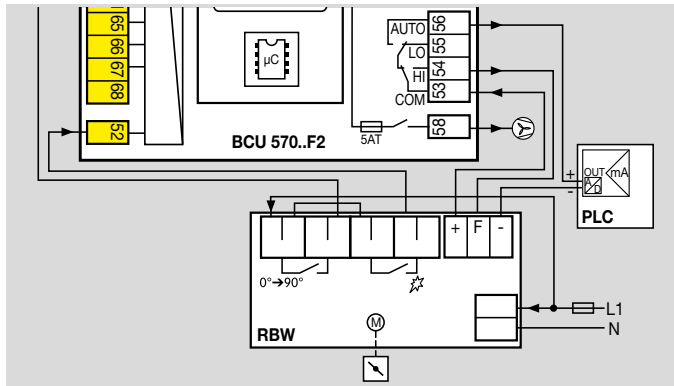
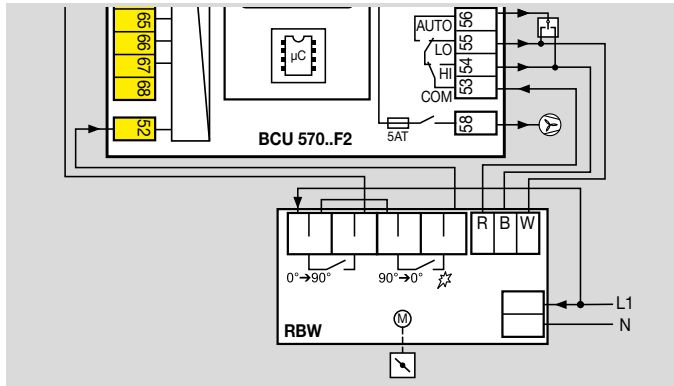

The RBW actuator reports that it has reached the position for maximum capacity via a signal to terminal 51. The actuator reports that it has reached the position for minimum

capacity via a signal to terminal 52. The simultaneous activation of terminals 51 and 52 results in a fault lock-out of the BCU.

If parameter 41 = 0, the system monitors the movement to the positions for maximum and minimum capacity with a timeout time of 255 s. Reaching the relevant position immediately triggers the program continue switch conditions. If reaching the position is not signalled within the timeout time of 255 s, a safety shut-down of the BCU will be performed. A fault message (Rc or Ro) will be displayed, see page 46 (9 Fault messages).

If parameter 41 = 1, the system does not monitor whether the positions for minimum and maximum capacity are reached. In this case, a running time of up to 250 s must be defined using parameter 42, see page 76 (10.6.9 Running time). The program continue switch conditions are then controlled dependent on this time.

If a fault occurs, the actuator is moved to the position for minimum capacity.

Manual mode

In Manual mode, no external controller is enabled during the controller enable procedure. The actuator can be moved to the positions for maximum capacity or ignition capacity by the user. 3-point step operation is not possible. No timeout is active when approaching these positions.

Frequency converter

Parameter 40 = 4: with frequency converter

The interface is configured according to the requirements of a frequency converter for fans.

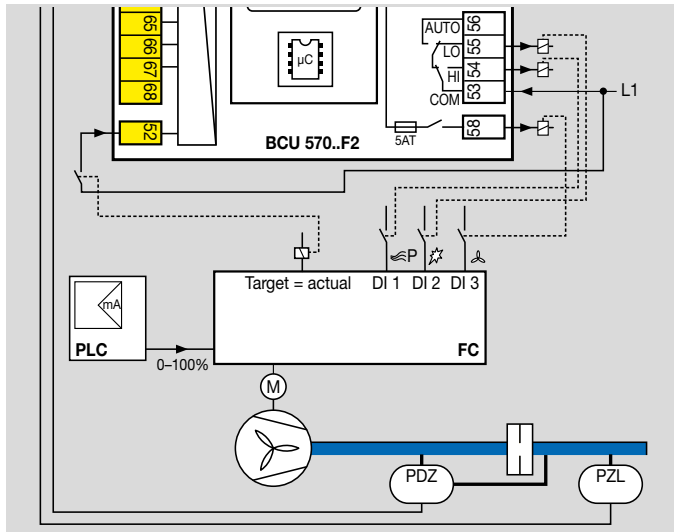

The BCU bridges the connections at terminals 53 and 54 (COM – HI bridge) for pre-purge. The frequency converter sets the fan to the speed for maximum capacity with a timeout of 255 s.

The frequency converter reports that the speed for maximum capacity has been reached by a signal (target = actual) to the BCU via terminal 52.

After the elapse of the pre-purge time, the BCU bridges the connections at terminals 53 and 55 (COM – LO bridge). The frequency converter accelerates the fan to the speed for minimum capacity (ignition capacity) with a timeout of 255 s. The frequency converter reports that the speed for mini-

um capacity (ignition capacity) has been reached by a signal (target = actual) via terminal 52. As soon as the burner operating signal has been received, the BCU bridges the connections at terminals 53 and 56 (COM – AUTO bridge). This disconnects the outputs at terminals 54 and 55 from the voltage supply to issue the controller enable signal to the frequency converter. During the controller enable procedure, the speed of the fan can be adjusted infinitely between minimum and maximum capacity using the analogue input of the frequency converter. There is no timeout active in this case.

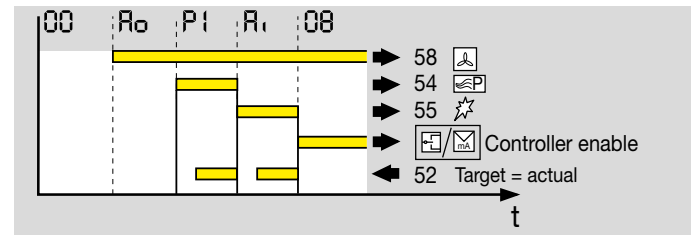

10 Parameter

BCU		Frequency converter		
Contact between terminals		Signal to	Position	Fan speed
53	55	DI 2/DI 3	Ignition	Minimum/ignition capacity
53	56	DI 3	0–20 mA	Any speed between minimum and maximum capacity
53	54	DI 1/DI 3	Purge	Maximum capacity

Manual mode

In Manual mode, the frequency converter can be set to the speed for maximum air volume or minimum air volume (pilot air volume). Adjustment by the control system is not possible. No timeout is active when approaching these speeds.

10.6.8 Running time selection

Parameter 41

This parameter can only be set on the BCU 570..F2 version in conjunction with an actuator with an RBW interface.

Parameter 41 = 0: Off; checking the positions for minimum/maximum capacity. A signal that the positions for minimum and maximum capacity have been reached is returned and monitored with a timeout time of max. 255 s. When the position has been reached, the BCU will initiate the next program step.

Parameter 41 = 1: On; for approaching the positions for minimum/maximum capacity. The running time set using parameter 42 is activated for approaching these positions, see page 76 (10.6.9 Running time). After this time has elapsed, the BCU will initiate the next program step.

Parameter 41 = 2: On; for approaching the position for maximum capacity. The running time set using parameter 42 is activated for approaching the position for maximum capacity, see page 76 (10.6.9 Running time). After this time has elapsed, the BCU will initiate the next program step. Approaching the position for minimum capacity is signalled and monitored.

Parameter 41 = 3: On; for approaching the position for minimum capacity. No signal is returned that the position for minimum capacity has been reached. The running time set using parameter 42 is activated for approaching the position for minimum capacity, see page 76 (10.6.9 Running time). After this time has elapsed, the BCU will initiate the next program step. Approaching the position for maximum capacity is signalled and monitored.

10.6.9 Running time

Parameter 42

Parameter 42 is only active if parameter 40 = 3 and parameter 41 = 1, 2 or 3.

This parameter is used to define the running time of the RBW actuator if it only signals one position or no positions (parameter 41 = 1, 2 or 3).

The program sequence of the burner control unit can be adapted to the closing properties of the actuator using this parameter.

The running time must be set such that the actuator can reach the position required for the next program step without any problems.

10.6.10 Low fire over-run

Parameter 43

This parameter can only be set on the BCU 570..F1 version in conjunction with an actuator IC 20 (P40 = 1).

The low fire over-run (t_{KN}) is applicable to systems with a pneumatic air/gas ratio control system and On/Off control. Using the low fire over-run function reduces the O_2 content in the furnace atmosphere. In addition, pressure peaks and thus tripping of safety devices in the event of a shut-down at high-fire rate are prevented.

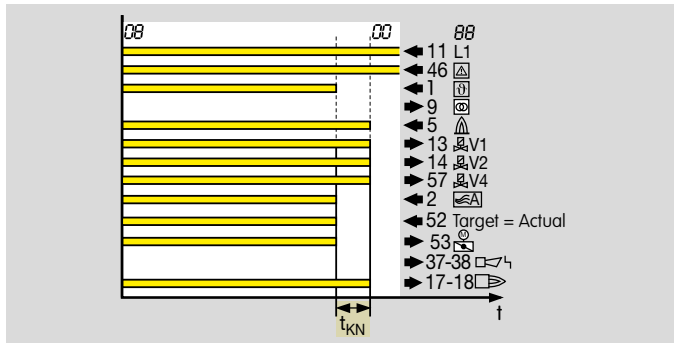

Parameter 43 = 0: Off. No low fire over-run is performed. The gas circuit is closed immediately owing to a quick closing gas valve in the case of On/Off control. Pressure peaks during this process can cause tripping of safety devices. The air circuit is closed more slowly. The air flowing in during this time increases the O_2 content in the combustion chamber.

Parameter 43 = 1 (only for BCU..F1/F2): up to minimum capacity. The burner is not immediately switched off after the start-up signal (terminal 1) has been removed. During low fire over-run, the control element is moved to the position for minimum capacity and the gas valves remain open until the

flame fails or the position for minimum capacity is reached. If the flame is extinguished, this does not result in a fault.

10.6.11 Controller enable signal delay time t_{RF}

Parameter 44

The controller enable signal is delayed by 0, 10, 20 or 30 up to 250 s using parameter 44.

If the BCU has successfully started the burner, after the elapse of the safety time and the flame proving period, if parameterized, the controller enable signal to the external temperature controller is delayed. The BCU shows program status *HB*. After the elapse of the delay time t_{RF} , the burner operation signalling contact (terminals 17, 18) is closed and the controller enable output (terminal 56) activated. The display changes to *BB*.

10.6.12 Capacity control (bus)

Parameter 75

Controlling the burner capacity using the fieldbus is only possible with bus module BCM 500 connected and enabled (P80 = 1 or 2).

Output terminal 56 is no longer available for controller enable if bus control is active.

Parameter 75 = 0: Off. No capacity control possible using the fieldbus.

Parameter 75 = 1: MIN. to MAX. capacity; standby in position for MIN. capacity. The control range while the burner is operating is between the positions for minimum capacity (S4) and maximum capacity (S3). The burner is ignited in the position for ignition capacity (S1). When the burner is switched off, the actuator is moved to the position for minimum capacity (S4).

This operating mode can be achieved with an actuator IC 20, RBW or alternatively with a comparable three-point step actuator.

If the air supply is stopped on a heated furnace with the burner switched off, the controls may be damaged by the hot furnace atmosphere as a result of the lowest possible position of the butterfly valve, limited by S4.

IC 20

Switching cam setting for ignition capacity, minimum and maximum capacity as well as pre-purge and standby:

S1: for ignition capacity of the burner.

S3: for maximum capacity of the burner and pre-purge.

S4: for minimum capacity of the burner and standby.

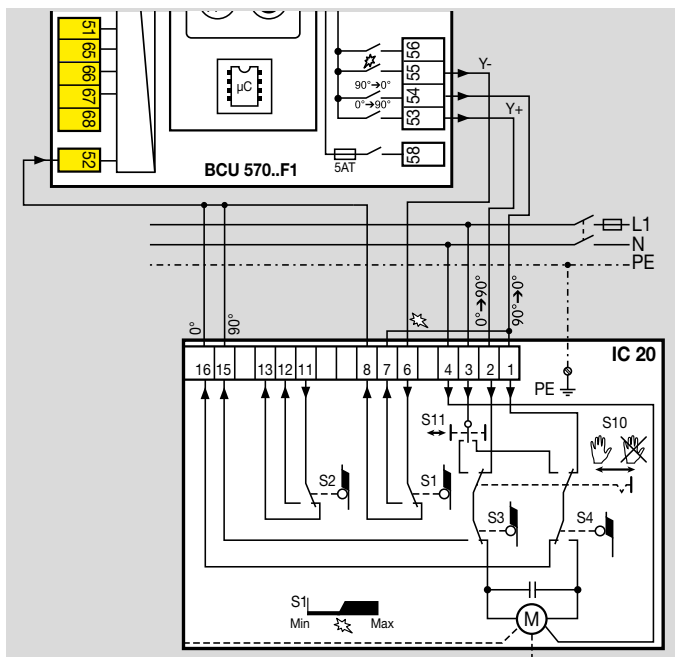
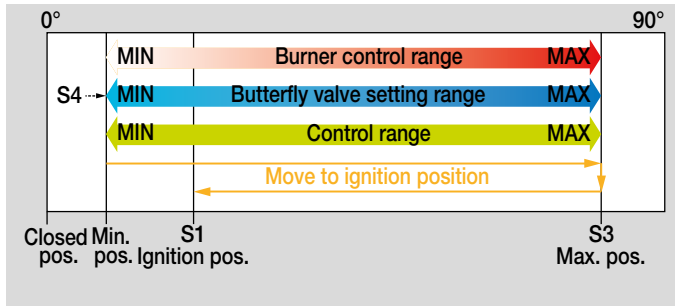

10 Parameter

Parameter 75 = 2: MIN. to MAX. capacity; standby in CLOSED position. The control range while the burner is operating is between the positions for minimum capacity (S2) and maximum capacity (S3). The burner is ignited in the position for ignition capacity (S1). When the burner is switched off, the actuator is moved to the closed position (S4).

This operating mode can be achieved with an actuator IC 20 or alternatively with a comparable three-point step actuator.

If the air supply is stopped on a heated furnace with the burner switched off, the controls are protected from the hot furnace atmosphere as a result of the butterfly valve being in the closed position (limited by S4). Check whether the burner can cope without cooling in this situation.

IC 20

Switching cam setting for ignition capacity, minimum and maximum capacity as well as pre-purge and standby:

S1: for ignition capacity of the burner.

S2: for minimum capacity of the burner.

S3: for maximum capacity of the burner and pre-purge.

S4: for the closed position of the butterfly valve and standby.

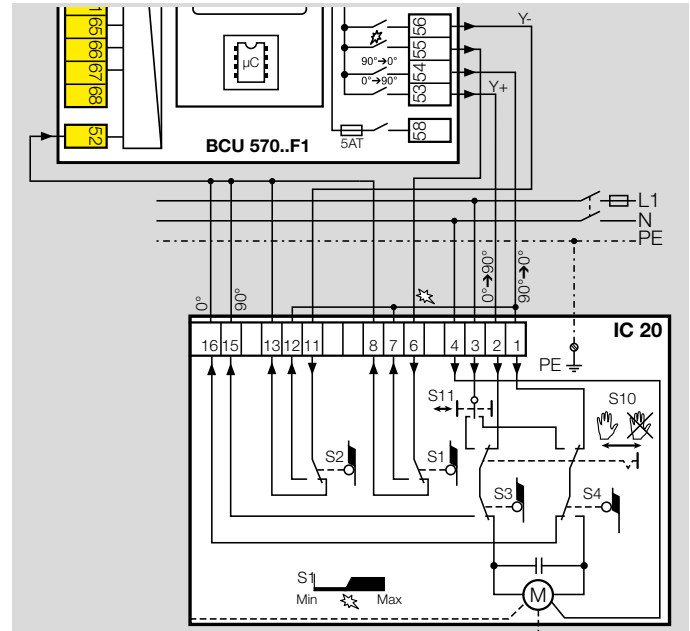
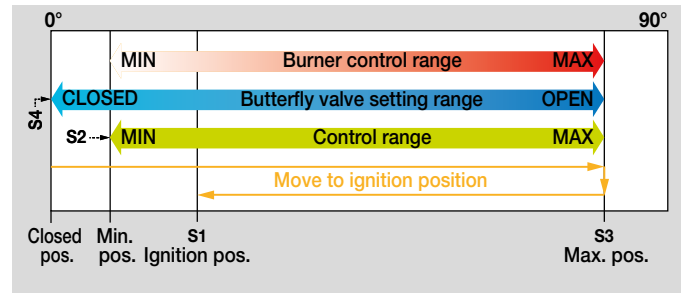

10 Parameter

Parameter 75 = 3: IGNITION to MAX. capacity; standby in CLOSED position.

The control range while the burner is operating is between the positions for minimum capacity (S1) and maximum capacity (S3). The burner is ignited in the position for minimum capacity (S1). When the burner is switched off, the actuator is moved to the closed position (S4).

This operating mode can be achieved with an actuator IC 20 or alternatively with a comparable three-point step actuator.

If the air supply is stopped on a heated furnace with the burner switched off, the controls are protected from the hot furnace atmosphere as a result of the butterfly valve being in the closed position (limited by S4). Check whether the burner can cope without cooling in this situation.

IC 20

Switching cam setting for ignition capacity, minimum and maximum capacity as well as pre-purge and standby:

S1: for minimum capacity and ignition capacity of the burner.

S3: for maximum capacity of the burner and pre-purge.

S4: for the closed position of the butterfly valve and standby.

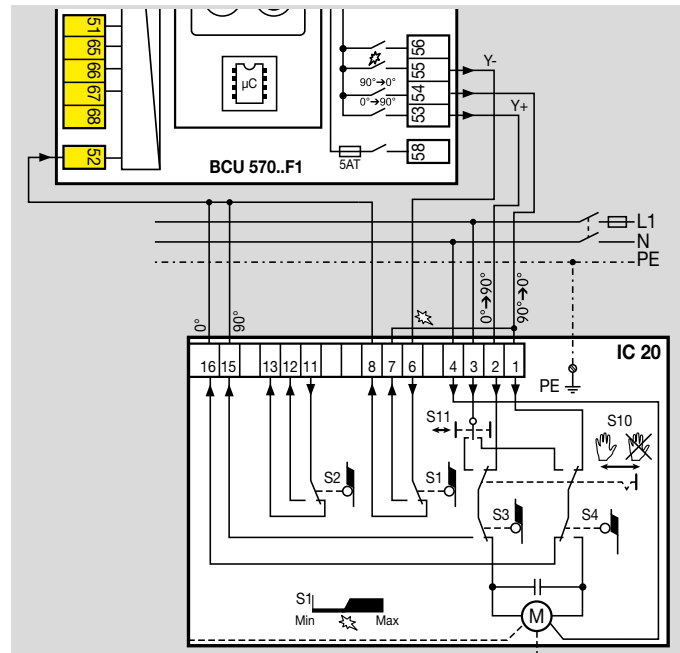
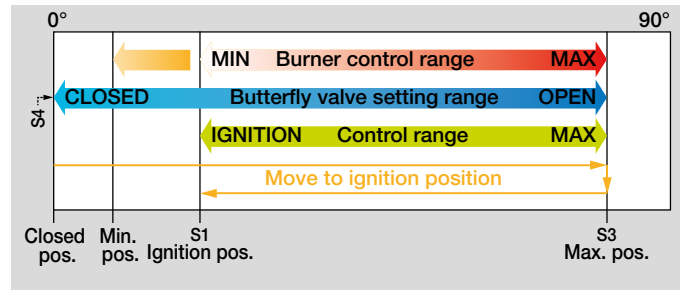

10 Parameter

Parameter 75 = 4: MIN. to MAX. capacity; standby in position for MIN. capacity; burner quick start.

The control range while the burner is operating is between the positions for minimum capacity (S4) and maximum capacity (S3). The burner is ignited in the position for minimum capacity (S1). Switching cam S2 (reverse direction of rotation) ensures that the position for ignition capacity is approached without pre-purging first (quick start). When the burner is switched off, the actuator is moved to the position for minimum capacity (S4).

This operating mode can be achieved with an actuator IC 20 or alternatively with a comparable three-point step actuator.

If the air supply is stopped on a heated furnace with the burner switched off, the controls may be damaged by the hot furnace atmosphere as a result of the lowest possible position of the butterfly valve, limited by S4. If pre-purge is active, considerably lower air capacity than the maximum air capacity will be used for purging.

IC 20

Switching cam setting for ignition capacity, minimum and maximum capacity and reverse direction of rotation to approach the position for ignition capacity:

S1: for ignition capacity of the burner.

S2: for reversing the direction of rotation to approach the position for ignition capacity.

S3: for maximum capacity of the burner and pre-purge.

S4: for the closed position of the butterfly valve and standby.

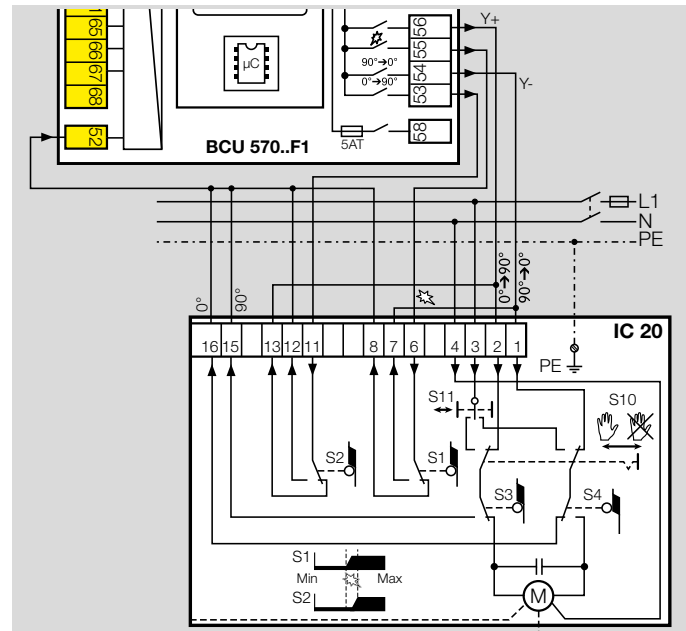
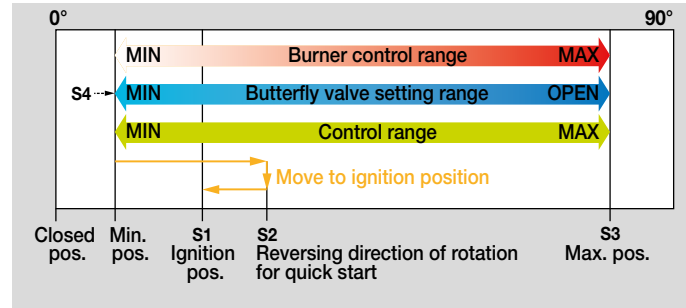

10 Parameter

Parameter 75 = 5: IGNITION to MAX. capacity; standby in CLOSED position; burner quick start.

The control range while the burner is operating is between the positions for ignition capacity (S1) and maximum capacity (S3). The burner is ignited in the position for ignition capacity (S1). Switching cam S2 (reverse direction of rotation) ensures that the position for ignition capacity is approached without pre-purging first (quick start). When the burner is switched off, the actuator is moved to the closed position (S4).

This operating mode can be achieved with an actuator IC 20 or alternatively with a comparable three-point step actuator.

If the air supply is stopped on a heated furnace with the burner switched off, the controls are protected from the hot furnace atmosphere as a result of the butterfly valve being in the closed position (limited by S4). Check whether the burner can cope without cooling. If pre-purge is active, considerably lower air capacity than the maximum air capacity will be used for purging.

IC 20

The position for maximum capacity is achieved by the controller enable output (terminal 56).

Switching cam settings S1, S2, S3 and S4:

S1: for minimum capacity and ignition capacity of the burner.

S2: for reversing the direction of rotation to approach the position for ignition capacity. The actuator will move to the position for ignition capacity without reaching the position for maximum burner capacity.

S3: for maximum capacity of the burner and pre-purge.

S4: for the closed position of the butterfly valve and standby.

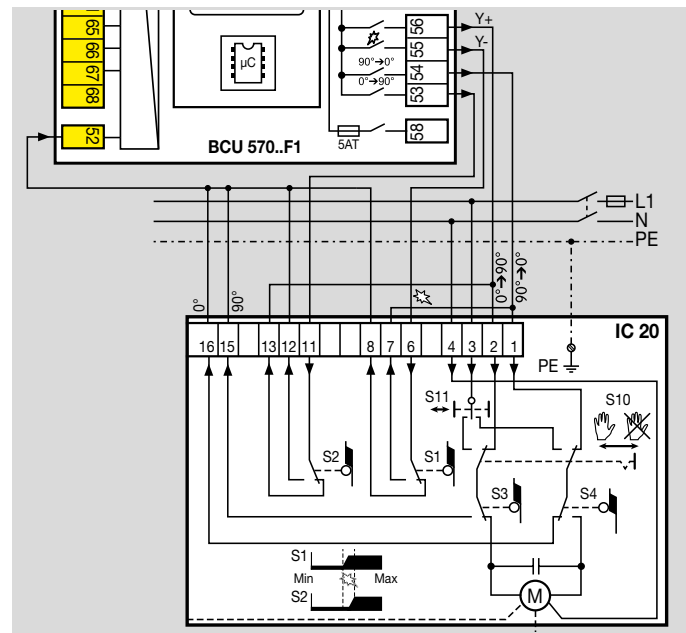
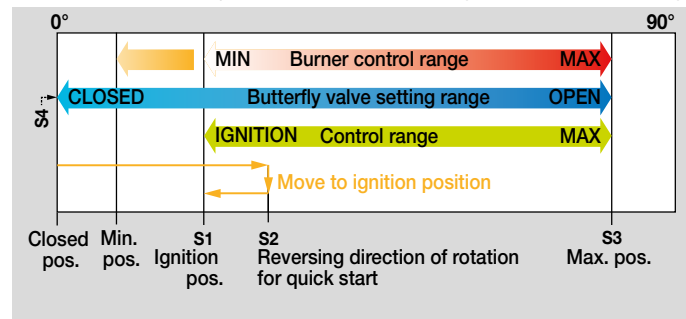

10.7 Valve check

10.7.1 Valve proving system

Parameter 51

Parameter 51 is used to define whether and at what time in the BCU program sequence the valve check is activated. This allows either the tightness of the gas solenoid valves and the pipework between them to be checked (tightness test) or the closed position of a solenoid valve (proof of closure function) to be checked. If the proof of closure function is activated, the closed position of the gas solenoid valve on the inlet side is checked using a POC switch.

Parameter 51 = 0: Off. No valve check is activated.

Parameter 51 = 1: tightness test before start-up.

Parameter 51 = 2: tightness test after shut-down. With this setting, a tightness test is also performed after a fault is reset and after mains on.

Parameter 51 = 3: tightness test before start-up and after shut-down.

An additional bypass/relief valve must be installed in gas sections with an air/gas ratio control. The valve allows the closed air/gas ratio control to be bypassed during the tightness test.

Parameter 51 = 4: proof of closure function (POC).

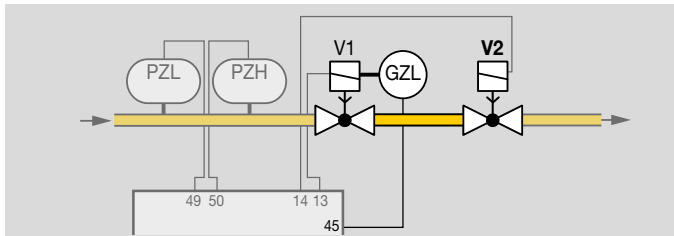

A signal is sent to the BCU via the POC switch on the gas solenoid valve on the inlet side before burner start-up stating that the valve is closed. After burner start-up, the signal must drop out to indicate to the BCU that the valve is open.

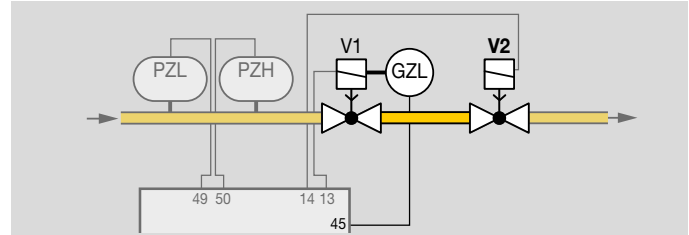

10.7.2 Relief valve (VPS)

Parameter 52

One of the valves connected to terminal 14, 15 or 57 can be selected to discharge the test volume during a tightness test.

Parameter 52 = 2: V2. The test volume is discharged via the valve connected to terminal 14.

Parameter 52 = 3: V3. The test volume is discharged via the valve connected to terminal 15.

Parameter 52 = 4: V4. The test volume is discharged via the valve connected to terminal 57.

10.7.3 Measurement time for V_{p1}

Parameter 56

The required measurement time must be determined according to the requirements of the appropriate application standards, e.g. EN 1643.

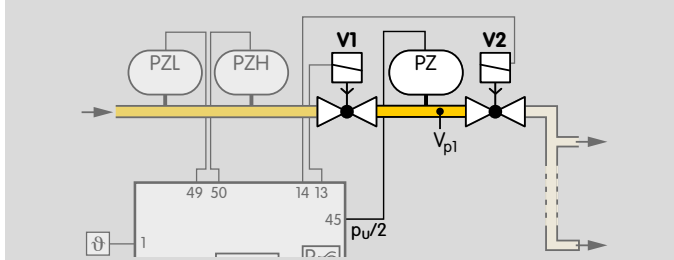

The required measurement time for the tightness test of V_{p1} can be set using parameter 56. The possible settings are 3 s, 5 to 25 s (in 5 s steps) or 30 to 3600 s (in 10 s steps). See also page 31 (5.2.2 Measurement time t_M).

10.7.4 Valve opening time 1 t_{L1}

Parameter 59

This parameter is used to define the opening time for the valves (2 to 25 s) which are opened to fill or discharge the test volumes between the gas valves.

If the preset opening time $t_L = 2$ s is inadequate (e.g. if slow opening valves are used) to fill the test volume or reduce the pressure between the valves, bypass valves can be used instead of the main valves.

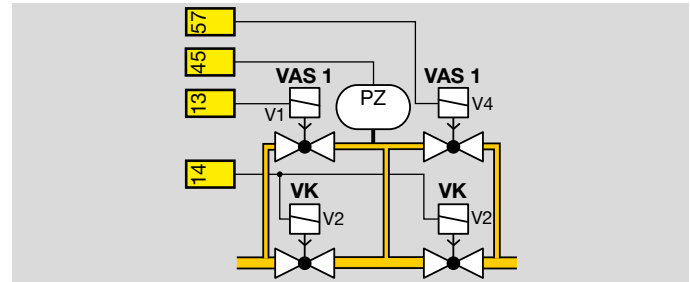

On condition that the gas volume which flows into the combustion chamber is no larger than 0.05% of the maximum flow rate, the bypass valves may be open for longer than the 3 s permitted by the standard (EN 1643:2000). The required volume limit can be achieved by fitting a restrictor or orifice, for example. The opening time to be set is then calculated on the basis of this restrictor or orifice.

Calculating the opening time, see www.adlatus.org, Extended valve opening time.

10.8 Behaviour during start-up

10.8.1 Minimum pause time t_{MP}

Parameter 62

A minimum pause time t_{MP} (0 to 3600 s) can be defined to achieve stable operation of the burners. If the post-ventilation time set using parameter 39 has elapsed and no start-up signal is received at terminal 1 (burner shut down), a restart and controlled air flow are prevented for the duration of the minimum pause time t_{MP} .

If a start-up signal is applied to terminal 1 (burner start-up) or terminal 2 (controlled air flow) during the minimum pause time, status display Delay HG will appear.

10.8.2 Switch-on delay time t_E

Parameter 63

Defines the time between applying the start-up signal (start or controlled air flow) and initiating the fan run-up time (0 to 25 s).

When several BCUs are activated simultaneously, setting different switch-on delay times t_E prevents the fans from starting at the same time and reduces the load on the power supply.

The switch-on delay also applies to the TC function. It is also active if the unit is switched on and the start-up signal was already present. If the switch-on delay is active, status display HG will appear. The switch-on delay can be set in the range from 0 to 250 s.

10.9 Manual mode

If the Reset/Information button is pressed for 2 s during switch-on, the BCU reverts to Manual mode. Two dots flash on the display. The BCU is now operating in Manual mode independently of the status of the inputs for start-up signal (terminal 1), controlled air flow (terminal 2) and remote reset (terminal 3). The functions of the safety-relevant inputs/controller enable/emergency stop (terminal 46) are retained. The manual start-up of the BCU can be initiated in Manual mode by pressing the Reset/Information button. Each time the button is pressed again, the BCU moves to the next step of the program sequence and stops there, for example for adjusting an actuator or the gas/air mixture.

Actuator IC 20, IC 40, RBW

Following controller enable (status display $\overline{0B}$), a connected actuator can be opened and closed as required. By holding the button, the actuator is first opened further. The BCU indicates $\overline{R0}$ with blinking dots. Once the button has been released, the actuator stops in the relevant position. Pressing it again will result in closing the actuator to the position for minimum capacity. The BCU indicates \overline{Rc} with blinking dots. A change of direction takes place each time the button is released and pressed again. When the actuator has reached its final position, the dots disappear.

Frequency converter

Following controller enable (status display $\overline{0B}$), the frequency converter can be set to the speed for maximum air volume or minimum air volume (pilot air volume) by pressing the button.

10.9.1 Operating time in Manual mode

Parameter 67

Parameter 67 determines when Manual mode is terminated.

Parameter 67 = 0: Manual mode is not limited in time.

If this function has been selected, operation of the burner may be continued manually in the event of failure of the control system or the bus activation.

Parameter 67 = 1: the BCU will terminate Manual mode 5 minutes after the last time the button is pressed. It then moves abruptly back to the start-up position (standby).

If the unit is switched off or a power failure occurs, Manual mode on the BCU will be terminated regardless of parameter 67.

10.10 Functions of terminals 51, 65, 66, 67 and 68

Terminals 51, 65, 66, 67 and 68 can each be assigned a logical AND gating with one of the inputs for the safety functions (terminals 46–50) using an appropriate parameter. If AND gating is required, the input concerned can be enabled.

Terminal 51 can also be used as a feedback input for the maximum capacity position when operated with IC 40/RBW.

10.10.1 Function of terminal 51

Parameter 69

Parameter 69 = 0: Off

Parameter 69 = 8: AND with input at terminal 46 (emergency stop)

Parameter 69 = 9: AND with input at terminal 47 (air_{min.} pressure switch)

Parameter 69 = 10: AND with input at terminal 48 (air flow pressure switch)

Parameter 69 = 11: AND with input at terminal 49 (gas_{max.} pressure switch)

Parameter 69 = 12: AND with input at terminal 50 (gas_{min.} pressure switch)

Parameter 69 = 13: max. capacity position feedback (IC 40/RBW), see page 68 (10.6.7 Capacity control).

10.10.2 Function of terminal 65

Parameter 70

Parameter 70 = 0: Off

Parameter 70 = 8: AND with input at terminal 46 (emergency stop)

Parameter 70 = 9: AND with input at terminal 47 (air_{min.} pressure switch)

Parameter 70 = 10: AND with input at terminal 48 (air flow pressure switch)

Parameter 70 = 11: AND with input at terminal 49 (gas_{max.} pressure switch)

Parameter 70 = 12: AND with input at terminal 50 (gas_{min.} pressure switch)

10.10.3 Function of terminal 66

Parameter 71

Parameter 71 = 0: Off

Parameter 71 = 8: AND with input at terminal 46
(emergency stop)

Parameter 71 = 9: AND with input at terminal 47
(air_{min.} pressure switch)

Parameter 71 = 10: AND with input at terminal 48
(air flow pressure switch)

Parameter 71 = 11: AND with input at terminal 49
(gas_{max.} pressure switch)

Parameter 71 = 12: AND with input at terminal 50
(gas_{min.} pressure switch)

10.10.4 Function of terminal 67

Parameter 72

Parameter 72 = 0: Off

Parameter 72 = 8: AND with input at terminal 46
(emergency stop)

Parameter 72 = 9: AND with input at terminal 47
(air_{min.} pressure switch)

Parameter 72 = 10: AND with input at terminal 48
(air flow pressure switch)

Parameter 72 = 11: AND with input at terminal 49
(gas_{max.} pressure switch)

Parameter 72 = 12: AND with input at terminal 50
(gas_{min.} pressure switch)

10.10.5 Function of terminal 68

Parameter 73

Parameter 73 = 0: Off

Parameter 73 = 8: AND with input at terminal 46
(emergency stop)

Parameter 73 = 9: AND with input at terminal 47
(air_{min.} pressure switch)

Parameter 73 = 10: AND with input at terminal 48
(air flow pressure switch)

Parameter 73 = 11: AND with input at terminal 49
(gas_{max.} pressure switch)

Parameter 73 = 12: AND with input at terminal 50
(gas_{min.} pressure switch)

10.10.6 Password

Parameter 77

The password is designed to protect the parameter settings. To prevent changes to parameter settings, a password is stored in parameter 77 (0000 to 9999). Changes to parameter settings can only be made once this number has been entered. The password can be changed using BCSoft. Note the effect of parameter settings on the safe functioning of your system.

10.10.7 Fieldbus communication

Parameter 80

Fieldbus communication can be enabled using parameter 80 when bus module BCM 500 is connected.

A device name/network name must be entered in the automation system/BCSoft for the unique identification of the control unit (BCU/FCU) in the fieldbus system.

Parameter 80 = 0: Off. Parameterization access using BCSoft via Ethernet is still possible.

Parameter 80 = 1: with address check. The device name/network name on delivery is "not-assigned- bcu-500-xxx". The expression "not-assigned-" must be deleted or may be replaced with an individual name. The sequence xxx must be identical to the address set on the BCM 500 using the code switches (xxx = address in the range 001 to FEF).



Parameter 80 = 2: no address check. The device name/network name can be selected as specified by the automation system.

11 Selection

Option	BCU
Series	570
Mains voltage	Q, W
Valve proving system	C0, C1
Capacity control	F1, F2
Flame control	U0
Connection terminals	K0, K1, K2

Order example

BCU 570WC1F1U0K1

11.1 Type code

BCU	Burner control unit
570	Series 570
Q	Mains voltage: 120 V AC, 50/60 Hz
W	Mains voltage: 230 V AC, 50/60 Hz
C0	No valve proving system
C1	Valve proving system
F1	Modulating with IC interface
F2	Modulating with RBW interface
U0	Ionization or UV control in case of operation with gas
K0	No connection plugs
K1	Connection plugs with screw terminals
K2	Connection plugs with spring force terminals
-E	Individual packaging

12 Project planning information

12.1 Installation

Installation position as required.

The BCU 570 mounting is designed for horizontally aligned 35 × 7.5 mm DIN rails.

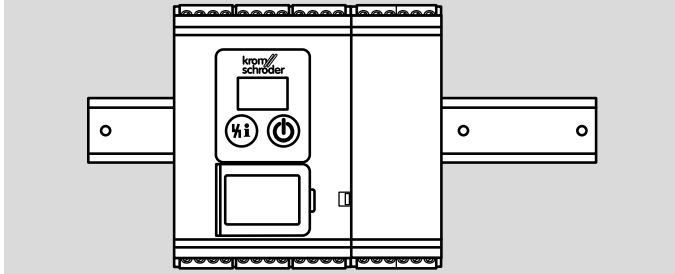

If the DIN rail is aligned vertically, end clamps are required (e.g. Clipfix 35 by Phoenix Contact) to prevent the BCU 570 from slipping.

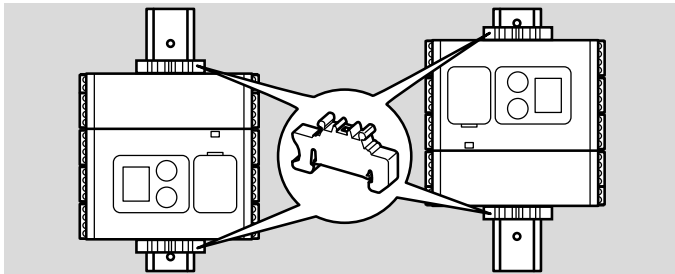

Environment

Install in a clean environment (e.g. a control cabinet) with an enclosure \geq IP 54, whereby no condensation is permitted.

12.2 Commissioning

Do not start the BCU 570 until the parameter settings and wiring are correct and the faultless processing of all input and output signals complies with the local standards.

12.3 Electrical connection

The BCU is designed for connection to a 1-phase system. All inputs and outputs have a one-phase mains supply. Other connected burner control units must use the same phase of the mains supply.

Signal and control line for screw terminals max. 2.5 mm² (AWG 12), for spring force terminals max. 1.5 mm² (AWG 16).

Do not route BCU cables in the same cable duct as frequency converter cables or cables emitting strong fields. External electrical interference must be avoided.

For information on the type of network, see page 105 (16 Technical data)

12.3.1 OCU

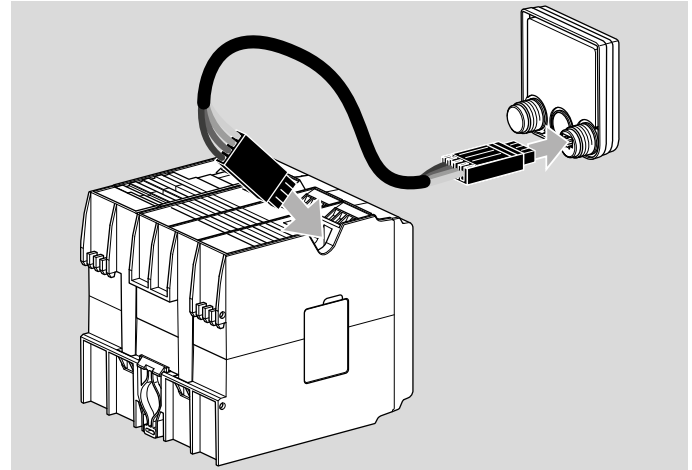

Cables for signalling and telecommunications systems are recommended for wiring the supplied plug connectors:
cable length: max. 10 m, 4-pin,
min. 0.25 mm² (AWG 24),
max. 0.34 mm² (AWG 22).

12.3.2 Safety current inputs

Actuation of the safety current inputs only with switchgear featuring mechanical contacts. If switchgear with semiconductor contacts is used, the safety current inputs must be connected using relay contacts.

To safeguard the safety current inputs, the fuse must be designed so that the sensor with the lowest switching capacity is protected.

The cabling outside enclosed installation spaces must be protected from mechanical damage and stress (e.g. vibration or bending) as well as short-circuits, short-circuits to ground and cross-circuits.

Calculation

I_N = current of the sensor/contactors with the lowest switching capacity

$$\text{Suitable fuse} = 0.6 \times I_N$$

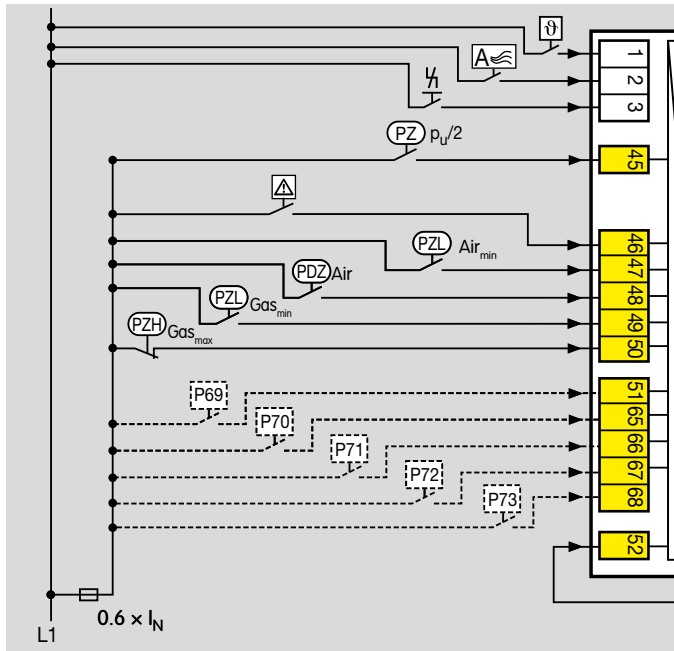

12.4 Actuators

If actuators are used, the start gas rate of the burners must be limited for SIL 3 applications in compliance with the standard.

12.4.1 IC 20

The BCU..F1 checks the position to which the actuator IC 20 has moved using terminal 52 (feedback) by lifting the signal to terminal 53, 54 or 55, see page 113 (20.10 Lifting). To ensure this check is possible, BCU..F1 and actuator IC 20 must be wired as shown in the connection diagram.

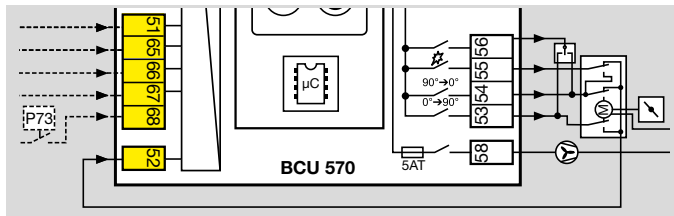

12.5 Air control

Starting the fan with the butterfly valve closed reduces the start-up current of the fan motor.

12.6 Parameter chip card

The parameter chip card must be installed in the unit for the BCU 570 to operate. The parameter chip card contains the valid parameter settings for the BCU 570. If a BCU 570 is replaced, the parameter chip card can be removed from the old unit and inserted into the new BCU 570. The BCU 570 must be disconnected from the electrical power supply for this purpose. The valid parameters are then adopted by the new BCU 570. The old device and the new BCU 570 must have an identical type code.

13 Accessories

13.1 BCSoft4

The current software can be downloaded from our Internet site at www.docuthek.com. To do so, you need to register in the DOCUTHEK.

13.1.1 Opto-adaptor PCO 200



Including BCSoft CD-ROM,
Order No.: 74960625.

13.2 OCU



For installation in the control cabinet door in standard grid dimensions. The program step/status or fault messages can be read on the OCU. In Manual mode, the OCU can be used to proceed through the sequence of operating steps. For details, see page 98 (14 OCU).

Type	Languages	Order No.
OCU 500-1	German, English, French, Dutch, Spanish, Italian	84327030
OCU 500-2	English, Danish, Swedish, Norwegian, Turkish, Portuguese	84327031
OCU 500-3	English, US English, Spanish, Brazilian Portuguese, French	84327032
OCU 500-4	English, Russian, Polish, Croatian, Romanian, Czech	84327033

13.3 Accessories set BCU 5xx/OCU

With 2 nuts (M22 x 1.5) and 2 O-rings to secure the OCU to a control cabinet door and 2 plugs for the electrical connection to the BCU. A 4-pin signal and control cable is required for the electrical connection. The maximum cable length must not exceed 10 m, the cable diameter must be between 0.25 mm² (AWG 24) and 0.34 mm² (AWG 22).

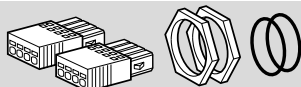

Accessories set BCU 5xx/OCU (spare part), Order No. 74966337.

13.4 Connection plug set

For wiring the BCU 570.

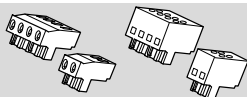

Connection plugs with screw terminals for BCU 570..K1
Order No.: 74923997.

Connection plugs with spring force terminals for BCU 570..

K2

Order No.: 74923999.

13.5 Stickers for labelling

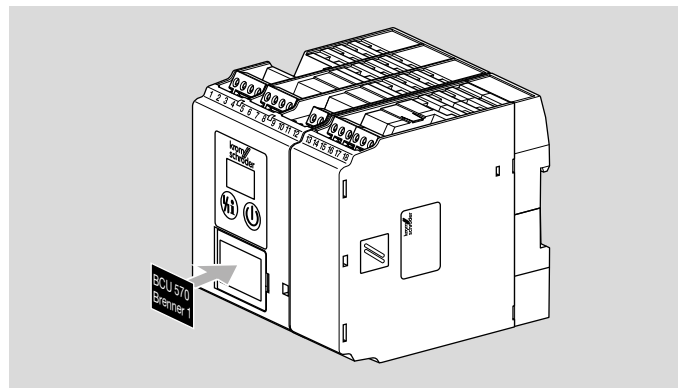

For printing with laser printers, plotters or engraving machines, 27 × 18 mm or 28 × 17.5 mm.

Colour: silver.

13.6 “Changed parameters” stickers

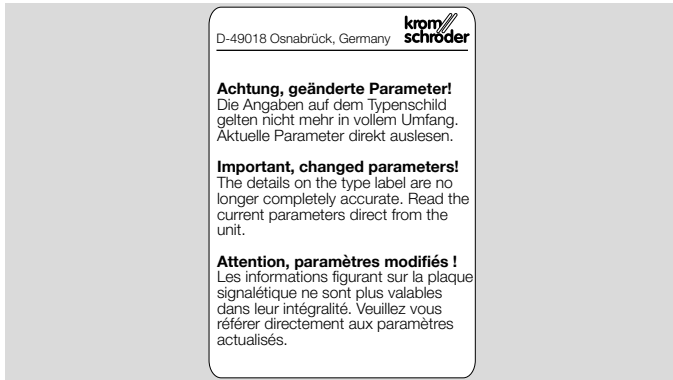

Affix on the connection diagram of the BCU 570 following changes to device parameters set at the factory.

100 pcs, Order No.: 74921492.

14 OCU

14.1 Application



The OCU is an external operator-control unit which can be connected to a control unit of the FCU 500/BCU 500 series. The external operator-control unit OCU is installed in the door of a control cabinet. Thus, the control cabinet does not need to be opened to read out process values, statistics, flame signal intensities or parameter values, to change settings on the OCU or to control or adjust connected valves in Manual mode.





14.2 Function

The OCU features an illuminated plain-text display. The lighting is switched on when a control key is pressed and switches off automatically after 5 minutes. In case of a fault lock-out or safety shut-down of the control unit, the OCU light starts blinking.

You can choose between the indicating ranges “status display” and “Service mode”.

The status display shows the program status or a fault message which has occurred in text form with the appropriate code.

The Service mode allows you to read out process values, parameter settings, information on the OCU or the statistics. In addition, you can operate connected control units in Manual mode. There are five control keys for the OCU and the control unit connected to it:

	Use the ON/OFF key to switch the control unit on or off.
	Use the Reset key to reset the control unit to its starting position in the event of a fault.
	Starting from the status display, you can use the OK key to change to Service mode.
	By holding down the key for a certain time, you can change directly to the status display.
	In Manual mode, those keys can be used to open and close an activated valve.

14.2.1 Manual mode

In Manual mode, the control unit works with capacity control (FCU..F1/F2 or BCU..F1/F2) regardless of the status of its inputs. The inputs for start-up signal (terminal 1), controlled air flow (terminal 2) and remote reset (terminal 3) are ignored. The function of the controller enable/emergency stop input (terminal 46) is retained.

The positions for maximum capacity, minimum capacity and ignition capacity of an actuator can be adjusted using the OCU. The OCU supports the process by means of a cyclic, automatic repeat approach to the selected position. The actuator can be moved within the menu to make changes to the cam settings.

After start-up has been completed, the navigation keys can be used, for example, to open or close a valve in program step 08.

14.3 Electrical connection

The OCU is to be connected to the control unit using the two plugs provided.

Required signal and control line:
cable length max. 10 m, 4-pin, min. 0.25 mm² (AWG 24),
max. 0.34 mm² (AWG 22).

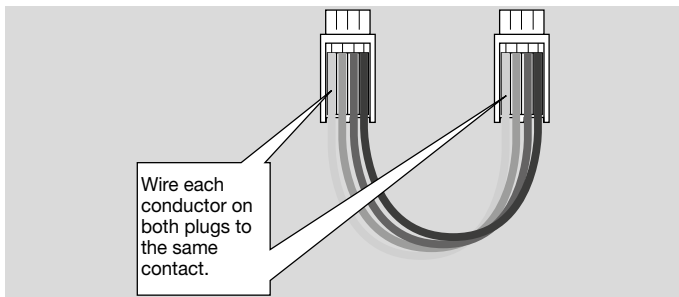
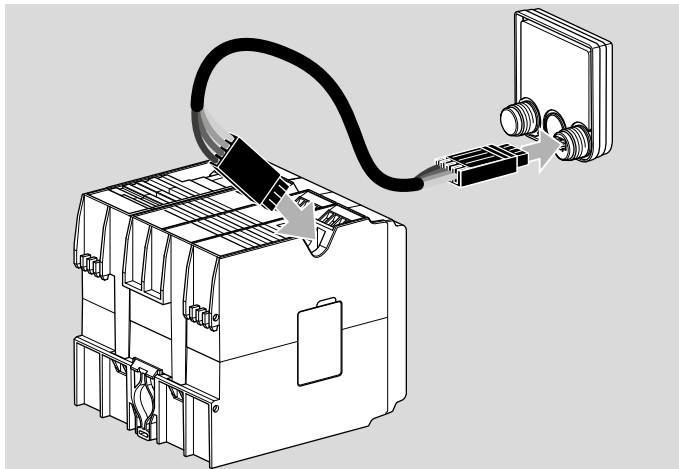

14.4 Installation

The threaded adapters of the OCU are suitable for 23 mm boreholes which are drilled at intervals of 30 mm.

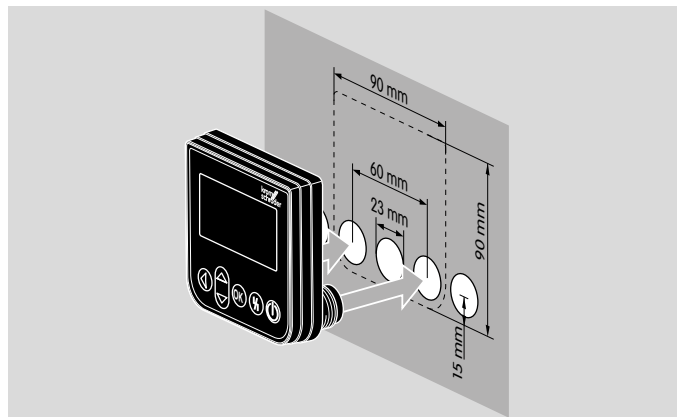

14.5 Selection

The OCU can be supplied with various language kits.

Type	Languages	Order No.
OCU 500-1	German, English, French, Dutch, Spanish, Italian	84327030
OCU 500-2	English, Danish, Swedish, Norwegian, Turkish, Portuguese	84327031
OCU 500-3	English, US English, Spanish, Brazilian Portuguese, French	84327032
OCU 500-4	English, Russian, Polish, Croatian, Romanian, Czech	84327033

14.6 Technical data for OCU

Ambient conditions

Avoid direct sunlight or radiation from red-hot surfaces on the unit.

Avoid corrosive influences, e.g. salty ambient air or SO₂.

This unit is not suitable for cleaning with a high-pressure cleaner and/or cleaning products.

Ambient temperature: -20 to +60°C.

Enclosure, mounted in the control cabinet door:

IP 65 for external part,

IP 40 for internal part.

Mechanical data

Number of operating cycles of the control keys: 1000.

Weight: 120 g.

Electrical data

Required signal and control line:

cable length max. 10 m, 4-pin,

min. 0.25 mm² (AWG 24),

max. 0.34 mm² (AWG 22).

15 BCM 500

15.1 Application



The bus module BCM 500 is used as a communication interface for devices of the BCU/FCU 500 product family for connection to a fieldbus communication system (Profinet or Modbus TCP). Networking via the fieldbus enables the FCU or BCU to be controlled and monitored by an automation system (e.g. PLC).

15.2 Function

The bus system transfers the control signals for starting, re-setting and for controlling the air valve to purge the furnace or kiln or for cooling in start-up position and heating during operation from the automation system (PLC) to the BCM. In the opposite direction, it sends operating status, the level of the flame signal and the current program step.

15.3 Electrical connection

Use only cable and plug components which comply with the appropriate PROFINET or Modbus TCP specifications.

Use shielded RJ45 plugs.

Cable length between 2 fieldbus subscribers: max. 100 m.

Installation guidelines

For PROFINET, see www.profibus.com,
for Modbus TCP, see www.modbus.org.

15.4 Installation

Installation position: vertically upright, horizontal or tilted to the left or right.

The BCM mounting is designed for horizontally aligned 35 x 7.5 mm DIN rails.

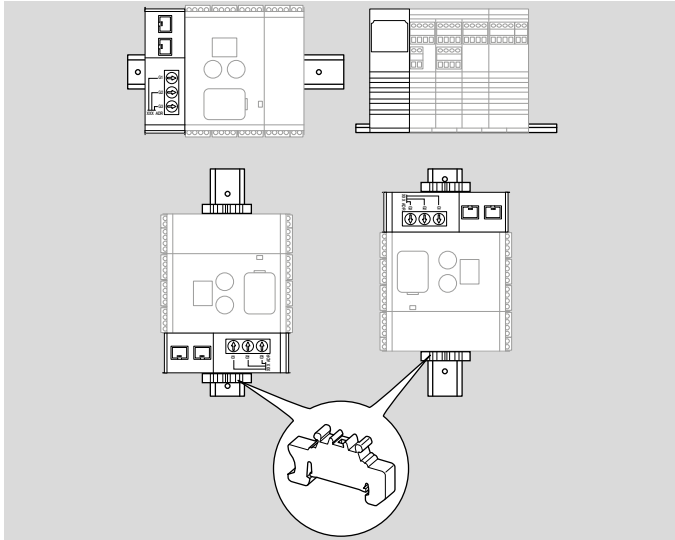

If the DIN rail is aligned vertically, end clamps are required (e.g. Clipfix 35 by Phoenix Contact) to prevent the control unit from slipping.

Install in a clean environment (e.g. a control cabinet) with an enclosure \geq IP 54, whereby no condensation is permitted.

15.5 Selection

Code	Description
BCM	Bus module

Code	Description
500	Series 500
S0	Standard communication
B2 B4	Profinet Modbus TCP
/3	Two RJ45 sockets
-3	Three-point step control via bus

BCM..B2, Order No.: 74960663

BCM..B4, Order No.: 74960688

15.6 Technical data for BCM

Electrical data

Power consumption: 1.2 VA.

Power loss: 0.7 W.

Mechanical data

Dimensions (W × H × D):

32.5 × 110 × 100 mm (1.28 × 4.53 × 3.94 inches),

H = 115 mm (4.5 inches) incl. DIN rail.

Weight: 0.3 kg.

Ambient conditions

Icing, condensation and dew in and on the unit are not permitted.

Avoid direct sunlight or radiation from red-hot surfaces on the unit.

Note the maximum medium and ambient temperatures!

Avoid corrosive influences, e.g. salty ambient air or SO₂.

Ambient temperature:

-20 to +60°C (-4 to +140°F).

Transport temperature = ambient temperature.

Storage temperature:

-20 to +60°C (-4 to +140°F).

Enclosure: IP 20 pursuant to IEC 529.

Installation location: min. IP 54 (for installation in a control cabinet).

Permitted operating altitude: < 2000 m AMSL.

16 Technical data

16.1 Electrical data

Mains voltage:

BCU 570Q: 120 V AC, -15/+10%, 50/60 Hz, $\pm 5\%$,
BCU 570W: 230 V AC, -15/+10%, 50/60 Hz, $\pm 5\%$,
for grounded or ungrounded mains.

UL-listed devices:

BCU 570Q: 120 V AC, -15/+10%, 50/60 Hz, $\pm 5\%$.

Flame control:

with UV sensor or flame rod.

For intermittent or continuous operation.

Flame signal current:

ionization control: 1–25 μA ,

UV control: 1–35 μA .

ionization/UV cable:

max. 100 m (328 ft).

Contact rating:

Valve outputs V1, V2, V3 and V4 (terminals 13, 14, 15, 57),
as well as actuator (terminals 53, 54 and 55):

max. 1 A each, $\cos \varphi \geq 0.6$.

Ignition transformer (terminal 9):

max. 2 A.

Total current for the simultaneous activation of the valve
outputs (terminals 13, 14, 15, 57), of the ignition transformer
(terminal 9) and of the actuator (terminals 53, 54, 56):

max. 2.5 A.

Fan (terminal 58):

max. 3 A (start-up current: $6 \text{ A} < 1 \text{ s}$).

Signalling contact for operating and fault signals:
max. 1 A (external fuse required).

Number of operating cycles:

The fail-safe outputs (valve outputs V1, V2, V3 and V4) are
monitored for correct functioning and are thus not subject
to a max. number of operating cycles.

Actuator (terminals 53, 54 and 55):

max. 250,000,

signalling contact for operating signals:

max. 250,000,

signalling contact for fault signals:

max. 10,000,

On/Off button:

max. 10,000,

Reset/Information button:

max. 10,000.

Input voltage of signal inputs:

Rated value	120 V AC	230 V AC
Signal "1"	80–132 V	160–253 V
Signal "0"	0–20 V	0–40 V

Signal input current:

Signal "1"	max. 5 mA
------------	-----------

Fuses, replaceable, F1: T 3.15A H,
F2: T 2A H, pursuant to IEC 60127-2/5.

Type of network

For grounded or ungrounded mains. The national stand-
ards and safety requirements must be satisfied. If the BCU
is operated in ungrounded/IT systems, an insulation moni-
toring device must be provided to isolate it from the mains
supply on all poles in the event of a fault. The cabling of the

16 Technical data

safety circuits (e.g. pressure switches, gas valves) outside enclosed installation spaces must be protected from mechanical damage and stress (e.g. vibration or bending) as well as short-circuits, short-circuits to ground and cross-circuits.

16.2 Mechanical data

Weight: 0.7 kg.

Connections

- Screw terminals:
nominal cross-section 2.5 mm²,
wire cross-section (rigid): min. 0.2 mm², max. 2.5 mm²,
AWG: min. 24, max. 12,
Contact rating: 12 A.
- Spring force terminals:
nominal cross-section 2 × 1.5 mm²,
wire cross-section: min. 0.2 mm², max. 1.5 mm²,
AWG: min. 24, max. 16,
Contact rating: 10 A (for UL 8 A).

16.3 Ambient conditions

Ambient temperature:

-20 to +60°C (-4 to +140°F),
no condensation permitted.

Enclosure: IP 20 pursuant to IEC 529.

Installation location: min. IP 54 (for installation in a control cabinet).

16.4 Dimensions

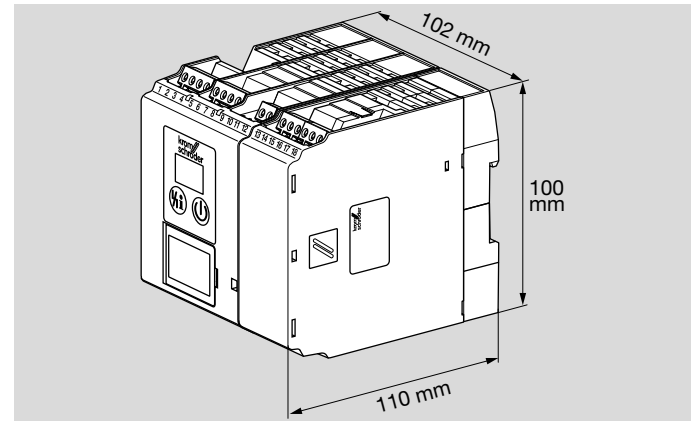

16.5 Safety-specific characteristic values

Certificates – see www.docuthek.com.

Pursuant to EN ISO 13849-1, Table 4, the BCU 570 can be used up to PL e.

Suitable for Safety Integrity Level	Up to SIL 3
Diagnostic coverage DC	98.8%
Type of subsystem	Type B to EN 61508-2:2010
Mode of operation	High demand mode pursuant to EN 61508-4:2010
Mean probability of dangerous failure PFH _D	14.6 × 10 ⁻⁹ 1/h on BCU 570..F1, 13.2 × 10 ⁻⁹ 1/h on BCU 570..F2
Mean time to dangerous failure MT-TF _d	MTTF _d = 1/PFH _D
Safe failure fraction SFF	99.8%

Valve proving system	7.2 × 10 ⁻⁹ 1/h
Emergency stop	7.2 × 10 ⁻⁹ 1/h
Emergency stop with optional input	7.1 × 10 ⁻⁹ 1/h
Low air pressure protection	7.2 × 10 ⁻⁹ 1/h
Low air pressure protection with optional input	7.1 × 10 ⁻⁹ 1/h
Low gas pressure protection	7.2 × 10 ⁻⁹ 1/h
Low gas pressure protection with optional input	7.1 × 10 ⁻⁹ 1/h
High gas pressure protection	7.2 × 10 ⁻⁹ 1/h
High gas pressure protection with optional input	7.1 × 10 ⁻⁹ 1/h
Capacity control	7.2 × 10 ⁻⁹ 1/h
Air flow monitoring with optional input	7.1 × 10 ⁻⁹ 1/h
Flame control	8.7 × 10 ⁻⁹ 1/h
Approaching position for ignition capacity with IC 20	8.0 × 10 ⁻⁹ 1/h
Approaching position for ignition capacity with RBW	7.9 × 10 ⁻⁹ 1/h

SIL 3 is only achieved in conjunction with actuators IC 20 or RBW if a separate gas valve is used to limit the pilot gas rate, see page 55 (10.3.3 Burner application), parameter 78 = 1 or 3.

Relationship between the Performance Level (PL) and the Safety Integrity Level (SIL)

PL	SIL
a	–
b	1
c	1
d	2
e	3

Max. service life under operating conditions:
20 years after date of production.

For a glossary of terms, see page 111 (20 Glossary).

17 Converting units

See www.adlatus.org

18 Maintenance

The fail-safe outputs (valve outputs V1, V2 and V3) of the power module are monitored for correct functioning. In the event of a fault, the system is set to a safe status using a second shut-down path (isolation of the valve outputs from the mains). In the event of a defect (e.g. fault 36), the power module must be replaced.

See www.partdetective.de (optimized for smartphones) for a replacement/order option for the power module.

The device and user statistics can be displayed using the operator-control unit OCU or engineering tool BCSOft for further diagnostics and troubleshooting. The user statistics can be reset using engineering tool BCSOft.

19 Legend

Symbol	Description
	Ready for operation
	Safety interlocks (limits)
	Control element position check
LDS	Safety limits (limits during start-up = LDS)
	Controlled air flow
	Remote reset
	Gas valve
	Air valve
	Air/gas ratio control valve
	Pilot burner (burner 1)
	Main burner (burner 2)
	Purge
	External air control
	Burner flame signal
	Burner operating signal
	Fault signal
	Start-up signal
	Pressure switch for tightness control (TC)
	Pressure switch for maximum pressure
	Pressure switch for minimum pressure
	Differential pressure switch
	Actuator with butterfly valve

Symbol	Description
	Valve with proof of closure switch
	Fan
	Three-point step switch
	Input/Output, safety circuit
TC	Tightness control
$p_U/2$	Half of the inlet pressure
$p_U/4$	A quarter of the inlet pressure
$3p_U/4$	Three-quarters of the inlet pressure
p_U	Inlet pressure
p_d	Outlet pressure
V_{p1}	Test volume
I_N	Current consumption of sensor/contactator
t_L	Tightness control opening time
t_M	Measurement time during tightness test
t_P	Tightness control test period ($= 2 \times t_L + 2 \times t_M$)
t_{PN}	Post-purge time
t_{FS}	Flame proving period
t_{MP}	Minimum pause time
t_{NL}	Over-run time
t_{SA}	Safety time on start-up
t_{SB}	Safety time during operation
t_{VZ}	Pre-ignition time
t_{GV}	Fan run-up time
t_E	Switch-on delay time
t_{PV}	Pre-purge time
t_{RF}	Controller enable signal delay time

20 Glossary

20.1 Waiting time t_W

In standby, the waiting time t_W starts to elapse in the background. During this time, a self-test is conducted to detect errors in internal and external circuit components. The burner will not be started during the waiting time. Any burner start will be delayed by the BCU 570 until the waiting time has elapsed.

20.2 Ignition time t_Z

If no malfunction is detected during the waiting time t_W , the ignition time t_Z then starts to elapse. Voltage is supplied to the pilot gas valve and the ignition transformer and the burner is ignited. The duration of the ignition time is either 1, 2, 3 or 6 s (depending on safety time t_{SA1} selected).

20.3 Safety interlocks (Limits)

The limiters in the safety interlock (linking of all the relevant safety control and switching equipment for the use of the application, e.g. safety temperature limiter, minimum/maximum gas pressure) must isolate input () from the voltage supply.

20.4 Safety time on start-up t_{SA1}

This refers to the period of time between switching on and switching off of the gas valve, when no flame signal is detected. The safety time on start-up t_{SA1} (2, 3, 5 or 10 s) is the minimum operating time of the burner and burner control unit.

20.5 Safety time during operation t_{SB}

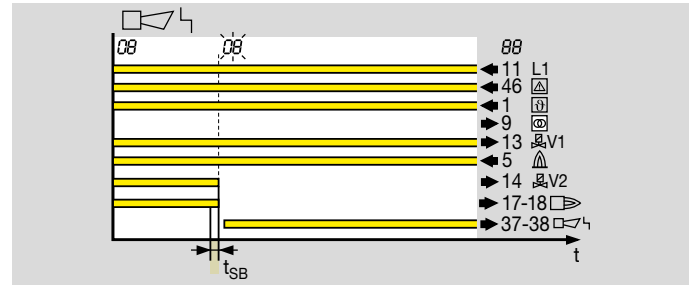

If the flame fails during operation, the output for valve V2 is disconnected within the safety time t_{SB} .

The default safety time during operation t_{SB} in accordance with EN 298 is 1 s. Under EN 746-2, the safety time of the installation during operation (including closing time of the valves) must not exceed 3 s. Note the requirements of the standards!

20.6 Safety shut-down

The burner control unit performs a safety shut-down immediately after receiving a signal from a safety device or after a fault is detected (e.g. flame or air pressure failure). The safety shut-down prevents operation of the burner by closing the fuel shut-off valves and deactivating the ignition device.

For this, the BCU 570 disconnects the gas valves and the ignition transformer from the electrical power supply. The operation signalling contact and the controller enable signal are deactivated. The fault signalling contact remains open. The display blinks and displays the current program step.

After a safety shut-down, the BCU 570 can restart automatically.

20.7 Fault lock-out

A fault lock-out is a safety shut-down with subsequent lock-out. The system can only be restarted following manual reset. The protective system cannot be reset by mains failure.

In the event of a fault lock-out of the BCU 570, the fault signalling contact closes, the display blinks and shows the current program step. The gas valves are disconnected from the electrical power supply. The fault signalling contact opens if the mains voltage fails.

In order to restart, the BCU 570 can only be reset manually using the button on the front panel, the OCU or the remote reset input (terminal 3).

20.8 Warning signal

The BCU 570 reacts to operating faults, e.g. in the case of permanent remote resets, with a warning signal. The display blinks and shows the corresponding warning message. The warning signal ends once the cause has been eliminated.

The program sequence continues. No safety shut-down or fault lock-out occurs.

20.9 Timeout

For some process faults, a timeout phase elapses before the BCU 570 reacts to the fault. The phase starts as soon as the BCU 570 detects the process fault and ends after 0 to 250 s. A safety shut-down or fault lock-out is then performed. If the process fault ends during the timeout phase, the process continues as before.

20.10 Lifting

After positioning the actuator IC 20, the BCU 570 checks by means of brief lifting whether its feedback input (terminal 52) has been activated by the correct output signal from the actuator. The signal of the relevant control output (ignition, OPEN, CLOSE) is switched off briefly for this purpose. While the signal is switched off, the BCU 570 may not detect a signal at the feedback input.

20.11 Air valve

The air valve can be used

- for cooling,
- for purging,

- to control the burner capacity in ON/OFF mode and in High/Low mode when using a pneumatic air/gas ratio control system.

20.12 Diagnostic coverage DC

Measure of the effectiveness of diagnostics, which may be determined as the ratio between the failure rate of detected dangerous failures and the failure rate of total dangerous failures

NOTE: Diagnostic coverage can exist for the whole or parts of a safety-related system. For example, diagnostic coverage could exist for sensors and/or logic system and/or final elements. Unit: %

see EN ISO 13849-1

20.13 Operating mode

IEC 61508 describes two modes of operation for safety functions. These are low demand mode and high demand or continuous mode.

In low demand mode, the frequency of demands for operation made on a safety-related system is not greater than one per year and is not greater than twice the proof-test frequency. In high demand mode or continuous mode, the frequency of demands for operation made on a safety-related system is greater than one per year or greater than twice the proof-test frequency.

See also IEC 61508-4

20.14 Safe failure fraction SFF

Fraction of safe failures related to all failures, which are assumed to appear

see EN 13611/A2

20.15 Probability of dangerous failure PFH_D

Value describing the likelihood of dangerous failure per hour of a component for high demand mode or continuous mode. Unit: 1/h

see EN 13611/A2

20.16 Mean time to dangerous failure $MTTF_d$

Expectation of the mean time to dangerous failure

see EN ISO 13849-1:2008

For more information

The Honeywell Thermal Solutions family of products includes Honeywell Combustion Safety, Eclipse, Exothermics, Hauck, Kromschroder and Maxon. To learn more about our products, visit ThermalSolutions.honeywell.com or contact your Honeywell Sales Engineer.

Elster GmbH
Strotheweg 1, D-49504 Lotte
T +49 541 1214-0
hts.lotte@honeywell.com
www.kromschroeder.com

© 2022 Elster GmbH

We reserve the right to make technical modifications in the interests of progress.

